

Central Coast Council



Central
Coast
Council

LANDSCAPE WORKS SPECIFICATION
DRAFT STANDARD DRAWINGS
2023

LANDSCAPE DESIGN AND CONSTRUCTION

COPYRIGHT OWNERSHIP IN THIS DOCUMENT BELONGS TO CENTRAL COAST COUNCIL UNLESS OTHERWISE INDICATED.

THE LANDSCAPE WORKS SPECIFICATION IS REFERENCED IN THE **CENTRAL COAST DEVELOPMENT CONTROL PLAN** AND CONSISTS OF THE FOLLOWING VOLUMES WHICH SHALL BE READ IN CONJUNCTION WITH ONE ANOTHER AS REQUIRED AND NOT IN ISOLATION. THESE DOCUMENTS ARE AVAILABLE ON COUNCIL'S WEBSITE ;

**STREET DESIGN MANUAL
CIVIL CONSTRUCTION SPECIFICATION
CIVIL STANDARD DRAWINGS**

STANDARD DRAWINGS PREPARED BY
CENTRAL COAST COUNCIL
ASSETS PLANNING AND DESIGN UNIT

WYONG OFFICE
2 Hely Street
WYONG NSW 2259

Central Coast Council



STANDARD DRAWING INDEX

DRAWING NUMBER	DRAWING TITLE	REVISION
LSD100	TREE PLANTING SERIES	
LSD101	STREET TREE IN TURF VERGE WITH TIMBER GUARD	A
LSD102	TIMBER TREE GUARD	A
LSD103	STREET TREE IN TURF WITH TIMBER STAKES	A
LSD104	STREET TREE IN ROAD FLUSH WITH ROAD LEVEL	A
LSD105	STREET TREE IN ROAD IN RAISED BLISTER	A
LSD106	TREES IN PARKS AND RESERVES	A
LSD107	TREES IN PAVEMENT	A
LSD108	TREES IN ROAD MEDIAN	A
LSD109	TREES IN CAR PARK – SHEET 1	A
LSD110	TREES IN CAR PARK – SHEET 2	A
LSD111	TREES IN BIORETENTION PIT	A
LSD200	GENERAL PLANTING SERIES	
LSD201	MASS PLANTING IN GARDEN BED	A
LSD202	TUBESTOCK PLANTING	A
LSD203	BIORETENTION BASIN PLANTING	A
LSD204	TURF	A
LSD300	EDGING SERIES	
LSD301	TIMBER GARDEN EDGE	A
LSD302	CONCRETE GARDEN EDGE	A
LSD303	UNIT PAVER EDGE	A
LSD400	PAVING SERIES	
LSD401	UNIT PAVER ON RIGID BASE	A

DRAWING NUMBER	DRAWING TITLE	REVISION
LSD500	PLAYGROUND SOFTFALL SERIES	
LSD501	PLAYGROUND SOFTFALL – BARK MULCH, SAND & RUBBER	A
LSD502	SOFTFALL EDGING	A
LSD600	FENCING SERIES	
LSD601	CHILD SAFETY FENCE	A
LSD700	FURNITURE SERIES	
LSD701	-	A
LSD800	SPECIFICATION SERIES	
LSD801	SOIL SPECIFICATION	A
LSD804	LANDSCAPE SPECIFICATION	A

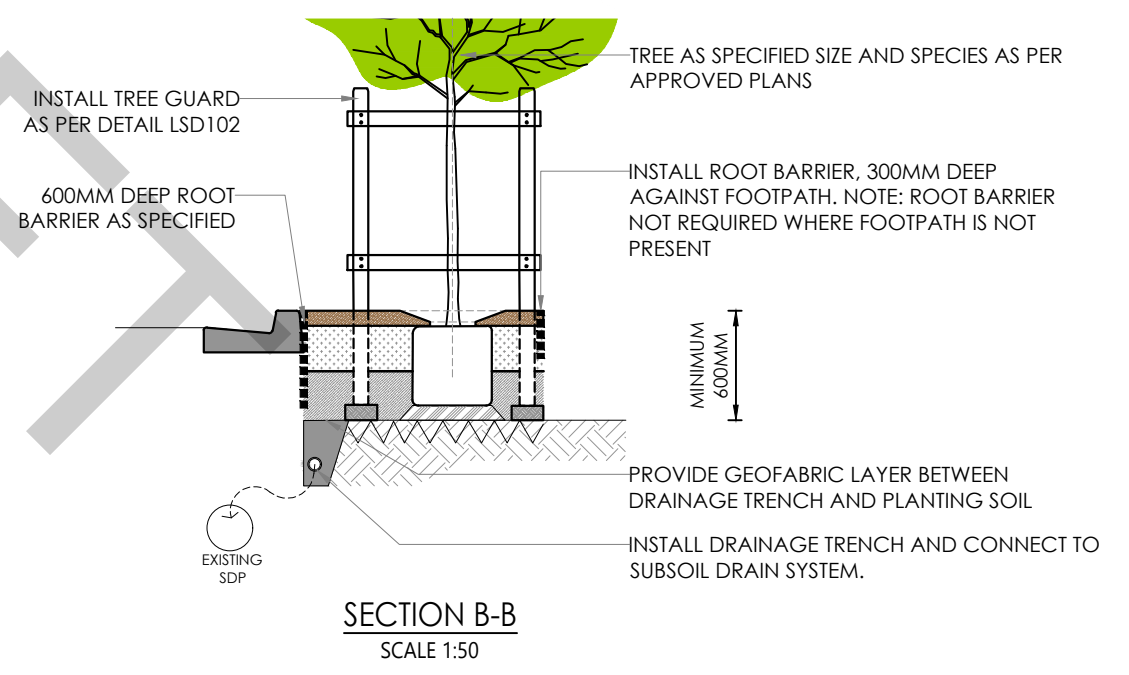
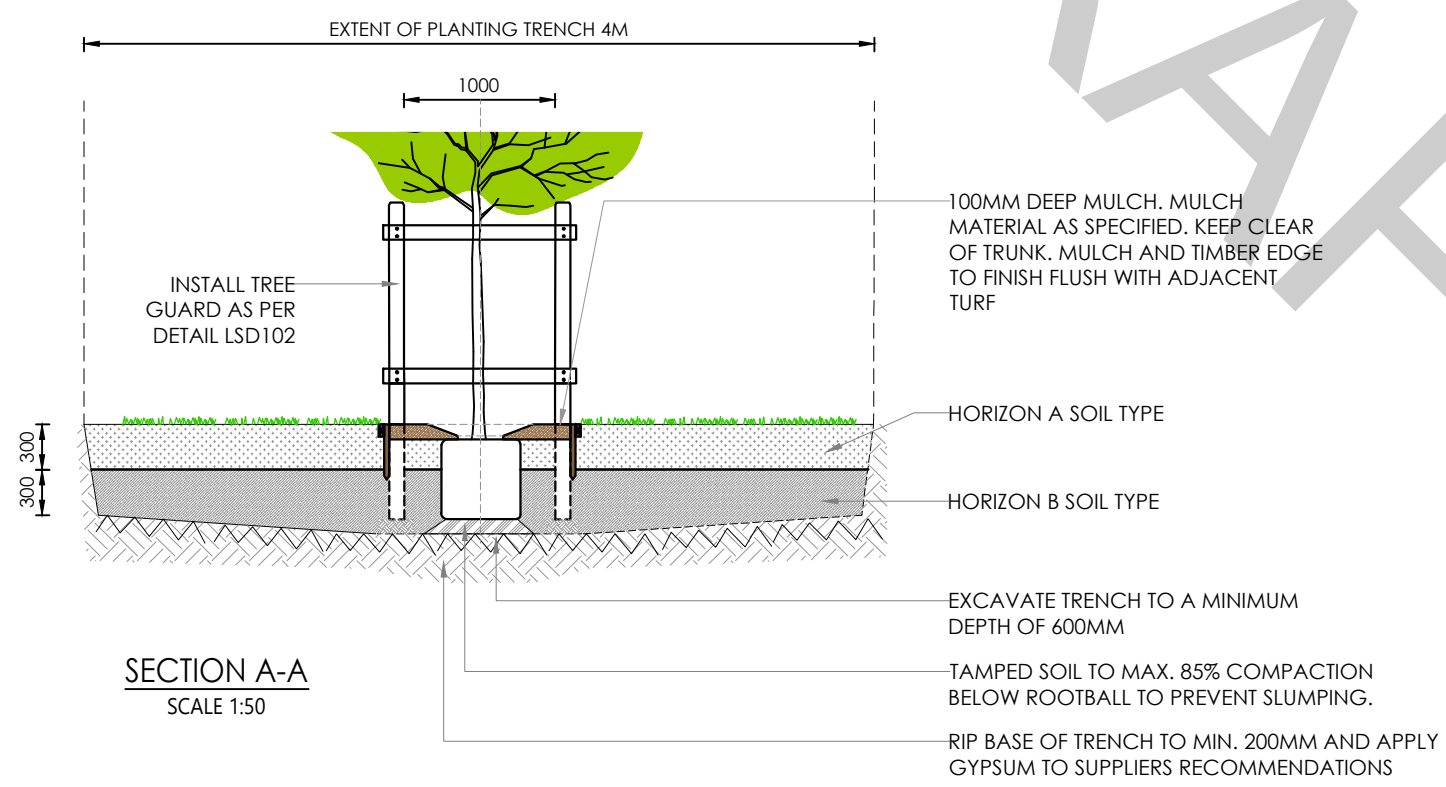
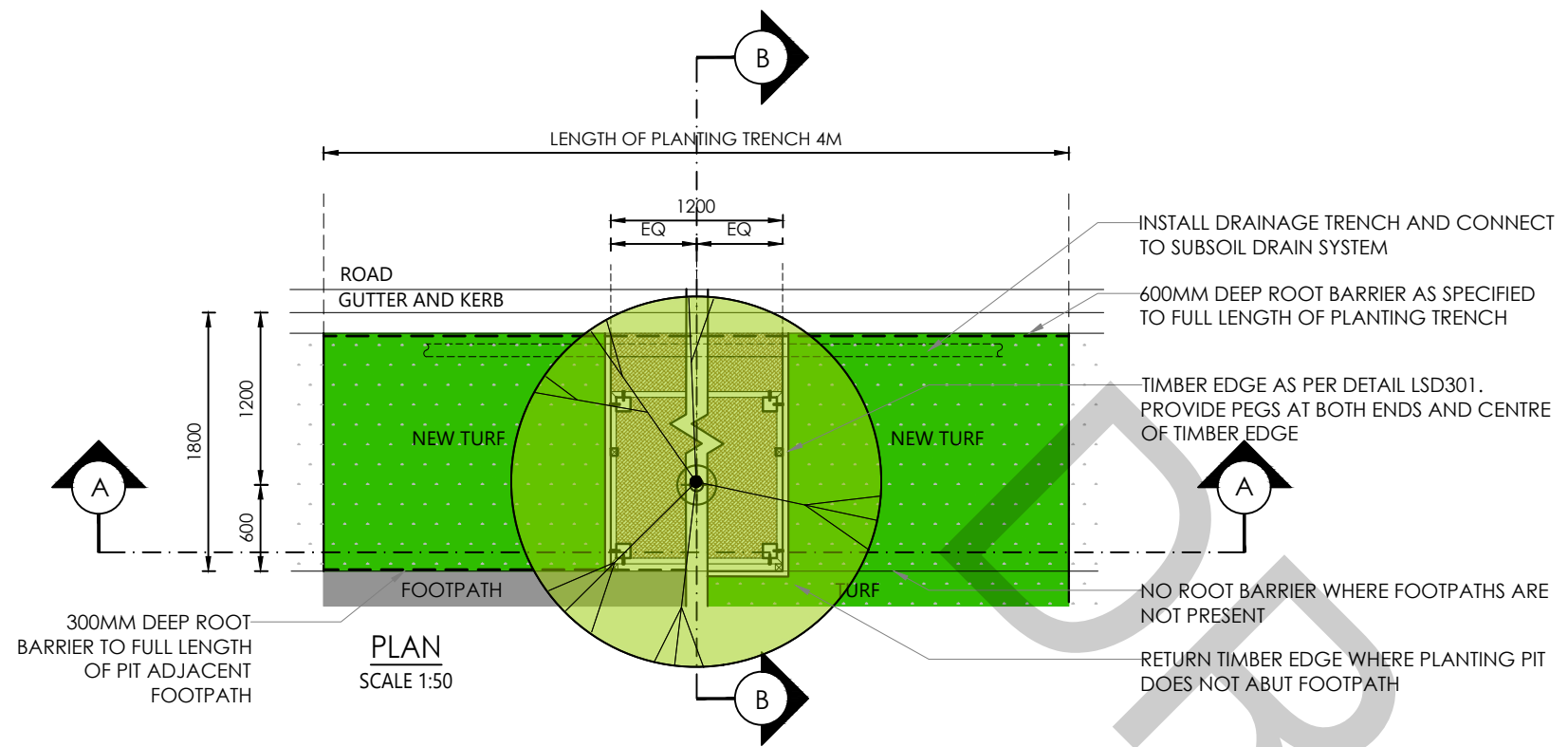

NOTES

1. TREE SUPPLY IN ACCORDANCE WITH AS2303. REFER TO CCC LANDSCAPE SPECIFICATION, SECTION 6 PLANT PROCUREMENT, FOR FURTHER DETAIL.
2. TREE SPECIES SUBSTITUTION REQUIRES WRITTEN CONSENT FROM CCC.
3. OBTAIN DBYD DRAWINGS PRIOR TO STARTING WORK.
4. GROUND TRUTH ALL POSSIBLE CONFLICTS WITH UNDERGROUND AND OVERHEAD SERVICES PRIOR TO COMMENCEMENT OF WORKS.
5. MINIMUM TREE INSTALLATION SIZE IS 75L UNLESS INDICATED IN CONDITIONS OF CONSENT.
6. REFER TO CCC SOIL SPECIFICATION LSD801 FOR SOIL PROPERTIES.
7. REFER TO CCC LANDSCAPE SPECIFICATION LSD802 FOR ALL PROGRAMMING, PLANTING, ESTABLISHMENT AND MAINTENANCE OPERATIONS REQUIREMENTS.

SCALE ON ORIGINAL A3 SIZE DRAWING					DRAWN -				CENTRAL COAST COUNCIL		STANDARD DRAWING	
0 500 1000 1500 2000 2500					CHECKED -							
1:50					DATE -				LSD101		A	
ALL DIMENSIONS IN mm UNLESS OTHERWISE SHOWN					UNIT MANAGER APPROVAL		ASSETS PLANNING AND DESIGN		TREE PLANTING SERIES		-	
									STREET TREE IN TURF VERGE WITH		A3	
									TIMBER GUARD			

NOTES

1. ALL TIMBER TO BE SUPPLIED DAR AND SEASONED.
2. FOR TIMBER IN CONTACT WITH GROUND, USE TIMBER WITH NATURAL DURABILITY CLASS 3 OR 4, TREATED TO H4 IN ACCORDANCE WITH AS1604.1 FOR ALL OTHER TIMBER, USE TIMBER WITH NATURAL DURABILITY CLASS 2-4 TREATED TO H3 IN ACCORDANCE WITH AS1604.1
3. ENSURE ALL SAW CUTS ARE PRESERVATIVE PAINT TREATED TO MAINTAIN REQUIRED HAZARD (H4/H3) CLASSIFICATION.
4. PAINT FINISH WITH EXTERIOR GRADE PAINT. UNDERCOAT AND TWO SURFACE COATS. PAINT COLOUR IN ACCORDANCE WITH APPROVED PLANS.

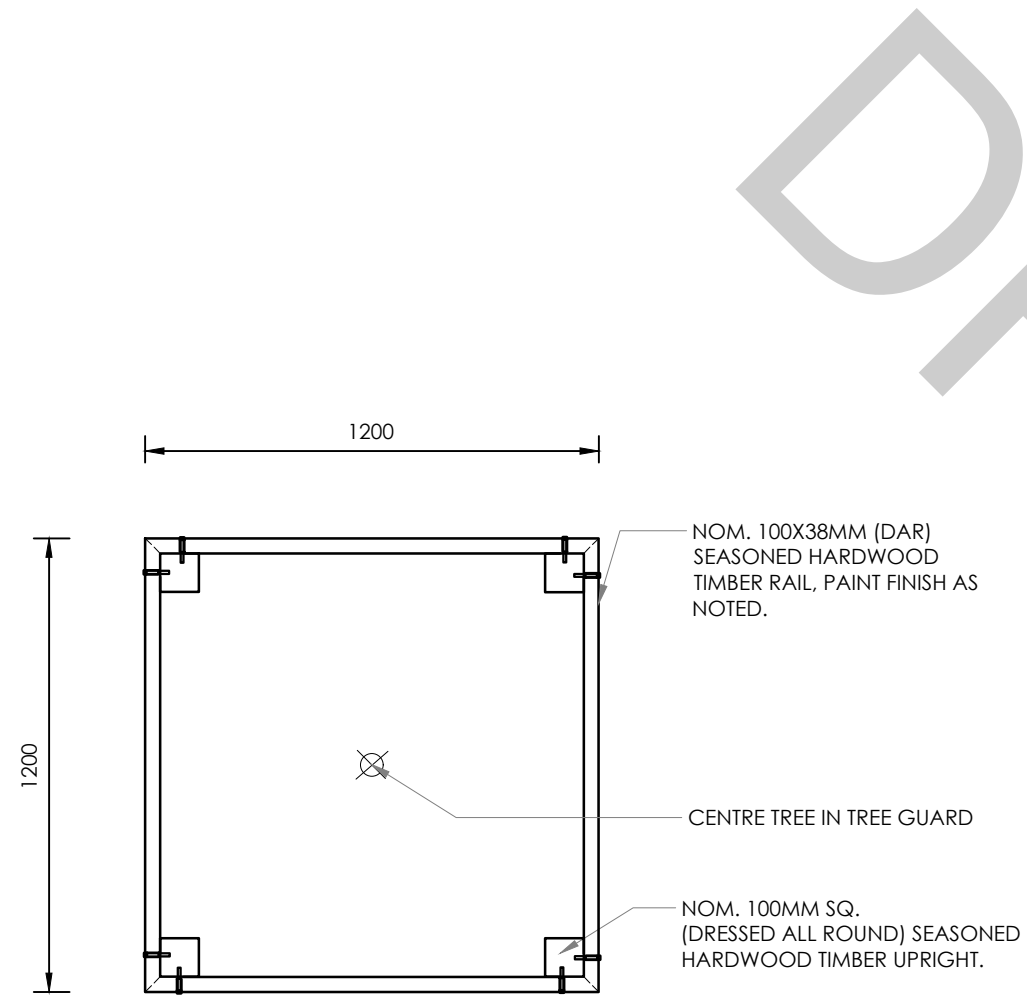

TREE GUARD PLAN
SCALE 1:20

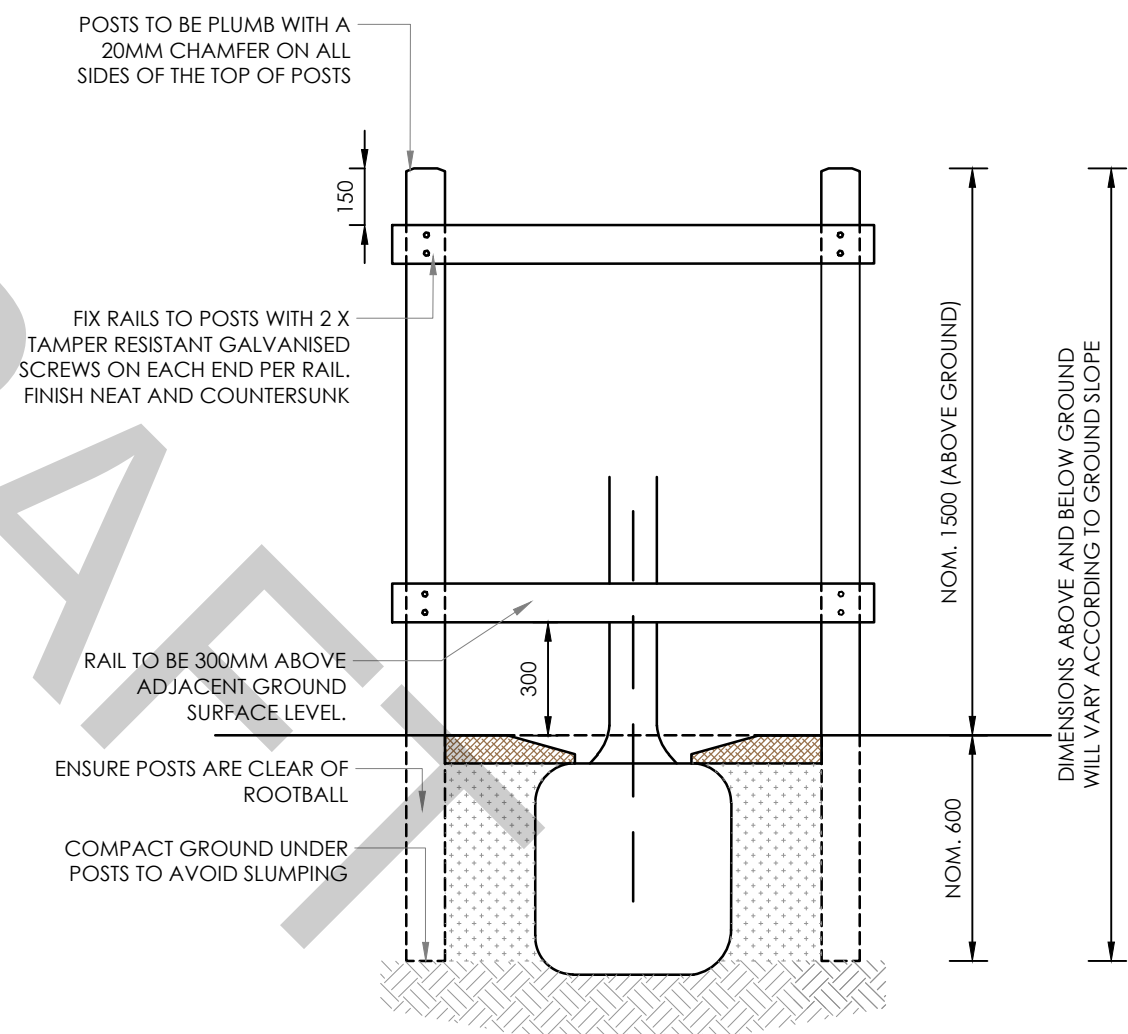

TREE GUARD ELEVATION
SCALE 1:20

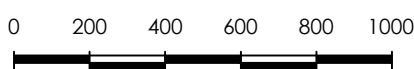
REV	AMENDMENT	DATE	DRAWN	APRVD	SCALE ON ORIGINAL A3 SIZE DRAWING	DRAWN	-		CENTRAL COAST COUNCIL	STANDARD DRAWING	
					 1:20	CHECKED	-			DRAWING NUMBER	REV
					ALL DIMENSIONS IN mm UNLESS OTHERWISE SHOWN	DATE	-	ASSETS PLANNING AND DESIGN	TREE PLANTING SERIES TIMBER TREE GUARD	LSD102	A
										-	A3

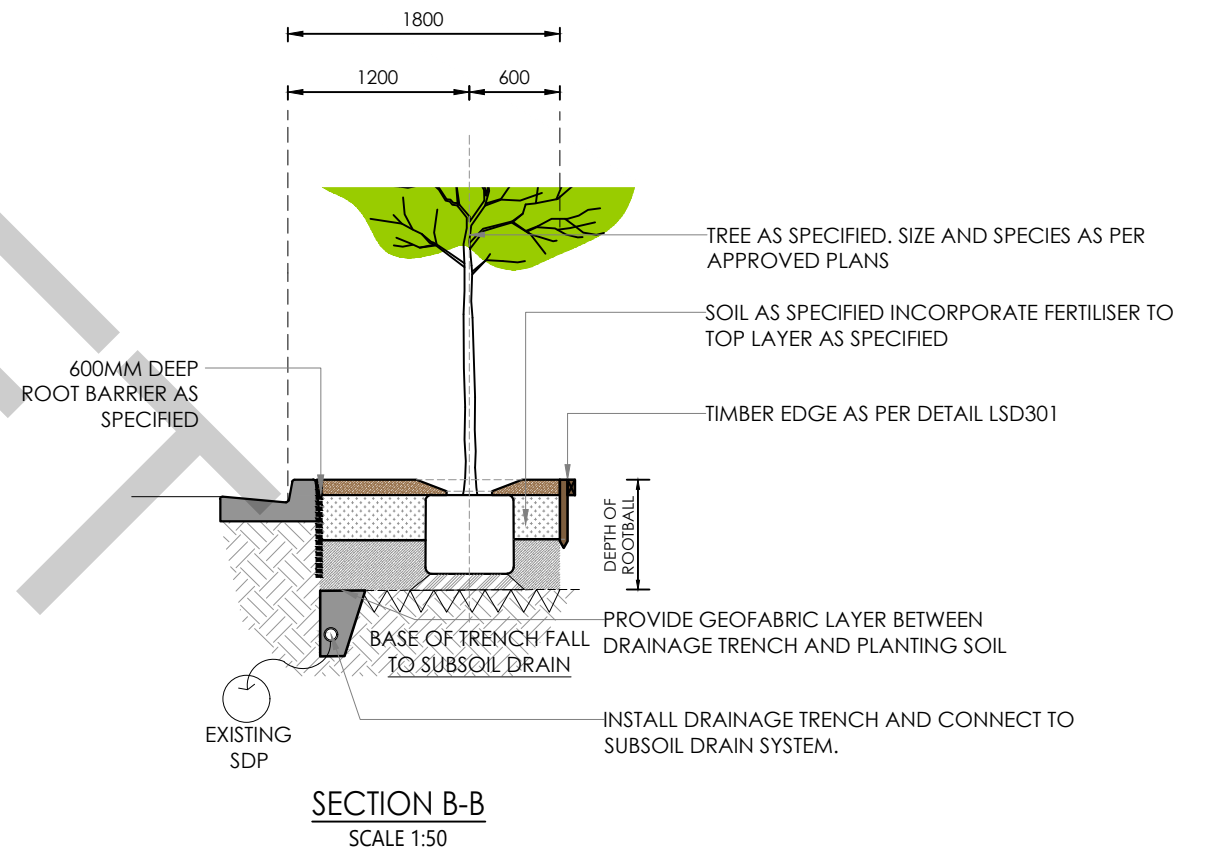
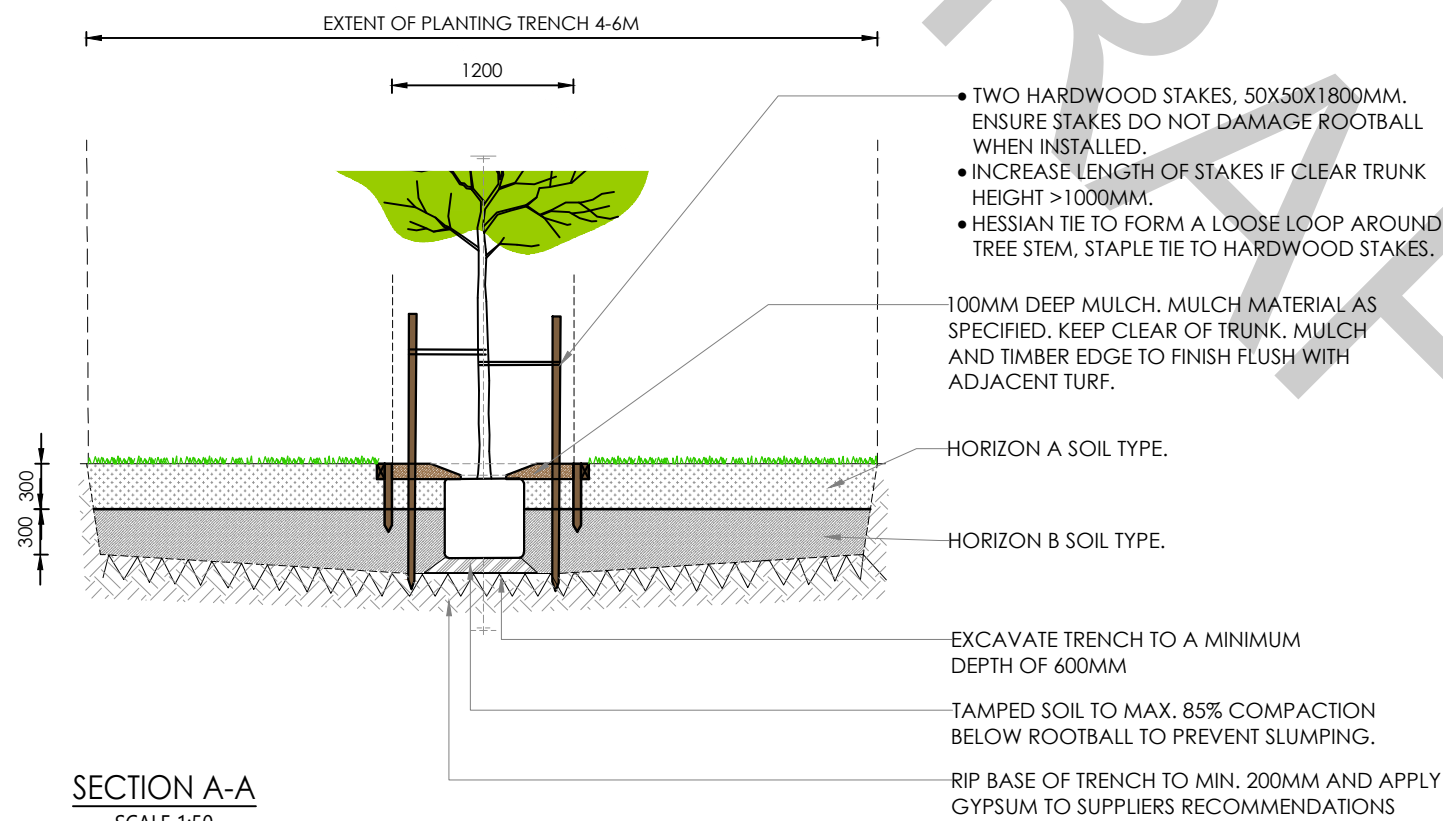
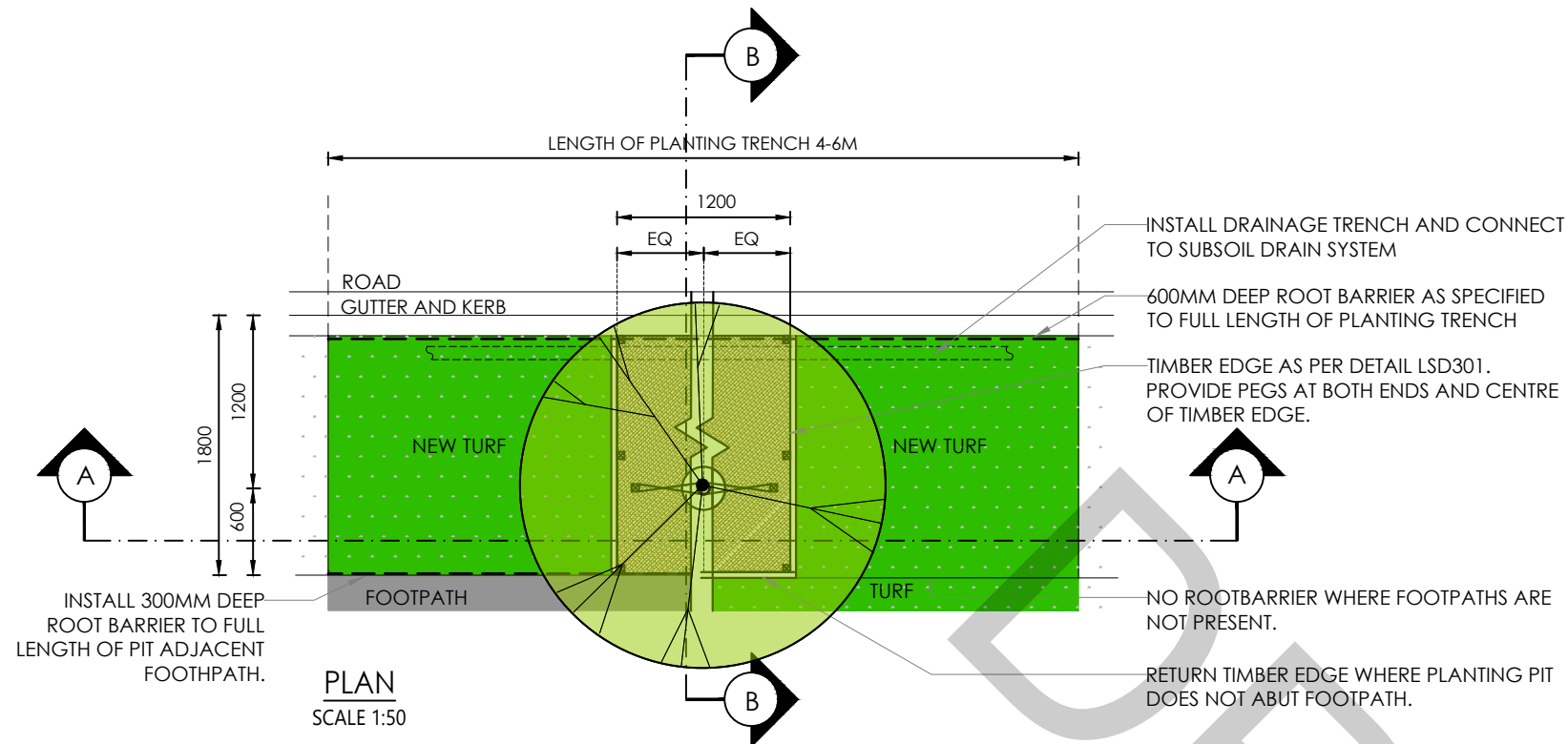

NOTES

1. TREE SUPPLY IN ACCORDANCE WITH AS2303. REFER TO CCC LANDSCAPE SPECIFICATION, SECTION 6 PLANT PROCUREMENT, FOR FURTHER DETAIL.
2. TREE SPECIES SUBSTITUTION REQUIRES WRITTEN CONSENT FROM CCC.
3. OBTAIN DBYD DRAWINGS PRIOR TO STARTING WORK.
4. GROUND TRUTH ALL POSSIBLE CONFLICTS WITH UNDERGROUND AND OVERHEAD SERVICES PRIOR TO COMMENCEMENT OF WORKS.
5. MINIMUM TREE INSTALLATION SIZE IS 75L UNLESS INDICATED IN CONDITIONS OF CONSENT.
6. REFER TO CCC SOIL SPECIFICATION LSD801 FOR SOIL PROPERTIES.
7. REFER TO CCC LANDSCAPE SPECIFICATION LSD802 FOR ALL PROGRAMMING, PLANTING, ESTABLISHMENT AND MAINTENANCE OPERATIONS REQUIREMENTS.

SCALE ON ORIGINAL A3 SIZE DRAWING

0 500 1000 1500 2000 2500

1:50

ALL DIMENSIONS IN mm UNLESS OTHERWISE SHOWN

DRAWN -
CHECKED -
DATE -

UNIT MANAGER APPROVAL

ASSETS PLANNING AND DESIGN



CENTRAL COAST COUNCIL

TREE PLANTING SERIES
STREET TREE IN TURF WITH TIMBER
STAKES

STANDARD DRAWING

DRAWING NUMBER REV

LSD103 A

- A3

REFER TO CCC ENGINEERING GUIDELINES AND STANDARD DETAILS FOR WHEELSTOPS

PIT CONFIGURATION TO PROVIDE MINIMUM 8M³ ROOT VOLUME.

EXTENT OF PIT (TYP). CONFIRM CELL CONFIGURATION WITH CELL SUPPLIER.

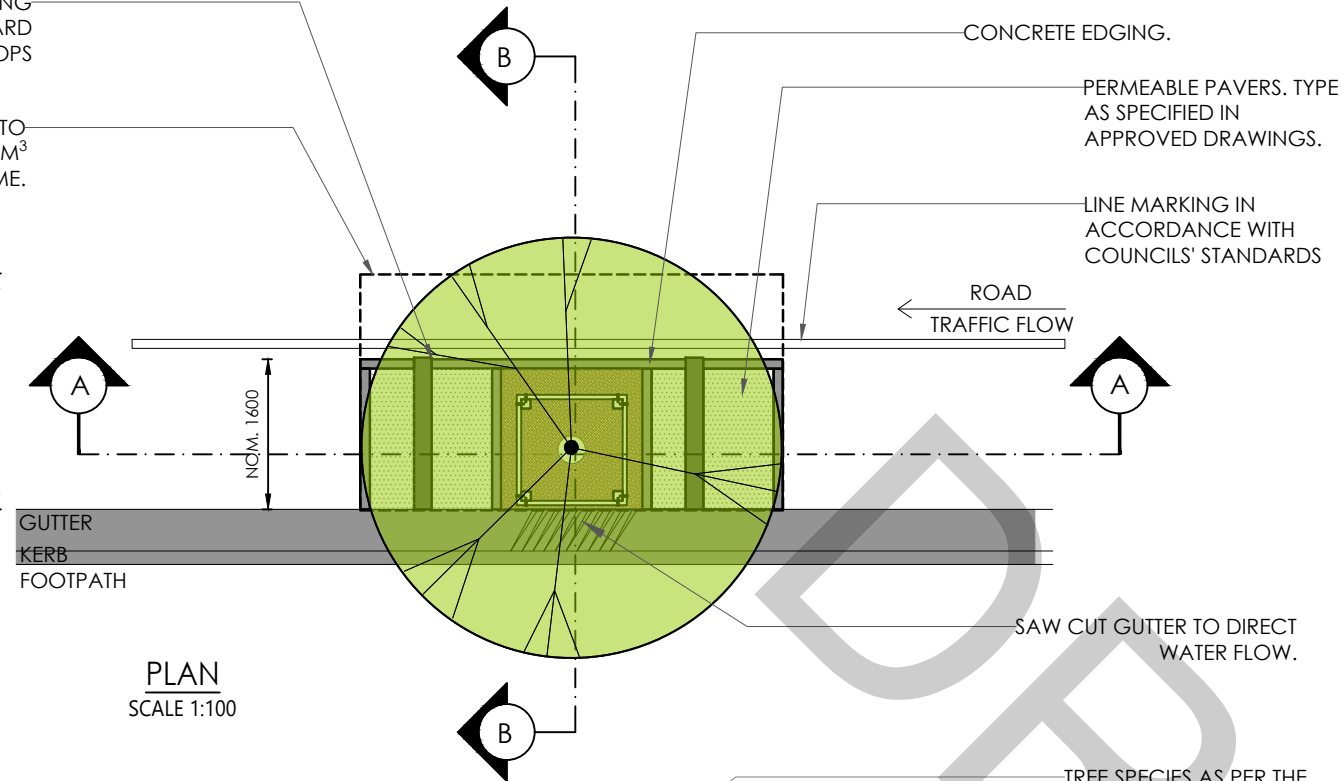

PLAN
SCALE 1:100

NOTES

1. TREE SUPPLY IN ACCORDANCE WITH AS2303. REFER TO CCC LANDSCAPE SPECIFICATION, SECTION 6 PLANT PROCUREMENT, FOR FURTHER DETAIL.
2. TREE SPECIES SUBSTITUTION REQUIRES WRITTEN CONSENT FROM CCC.
3. OBTAIN DBYD DRAWINGS PRIOR TO STARTING WORK.
4. GROUND TRUTH ALL POSSIBLE CONFLICTS WITH UNDERGROUND AND OVERHEAD SERVICES PRIOR TO COMMENCEMENT OF WORKS.
5. MINIMUM TREE INSTALLATION SIZE IS 75L UNLESS INDICATED IN CONDITIONS OF CONSENT.
6. CONFIRM COMPATIBILITY BETWEEN PIT DESIGN AND PAVEMENT DESIGN.
7. STRUCTURAL CELL PRODUCT MUST MEET COUNCILS REQUIREMENTS. THE STRUCTURAL CELL SYSTEM PROPOSED APPROVED BY COUNCIL'S PROJECT OFFICER PRIOR TO IMPLEMENTATION OF THE WORKS.
8. REFER TO CCC SOIL SPECIFICATION LSD801 FOR SOIL PROPERTIES.
9. REFER TO CCC LANDSCAPE SPECIFICATION LSD802 FOR ALL PROGRAMMING, PLANTING, ESTABLISHMENT AND MAINTENANCE OPERATIONS REQUIREMENTS.

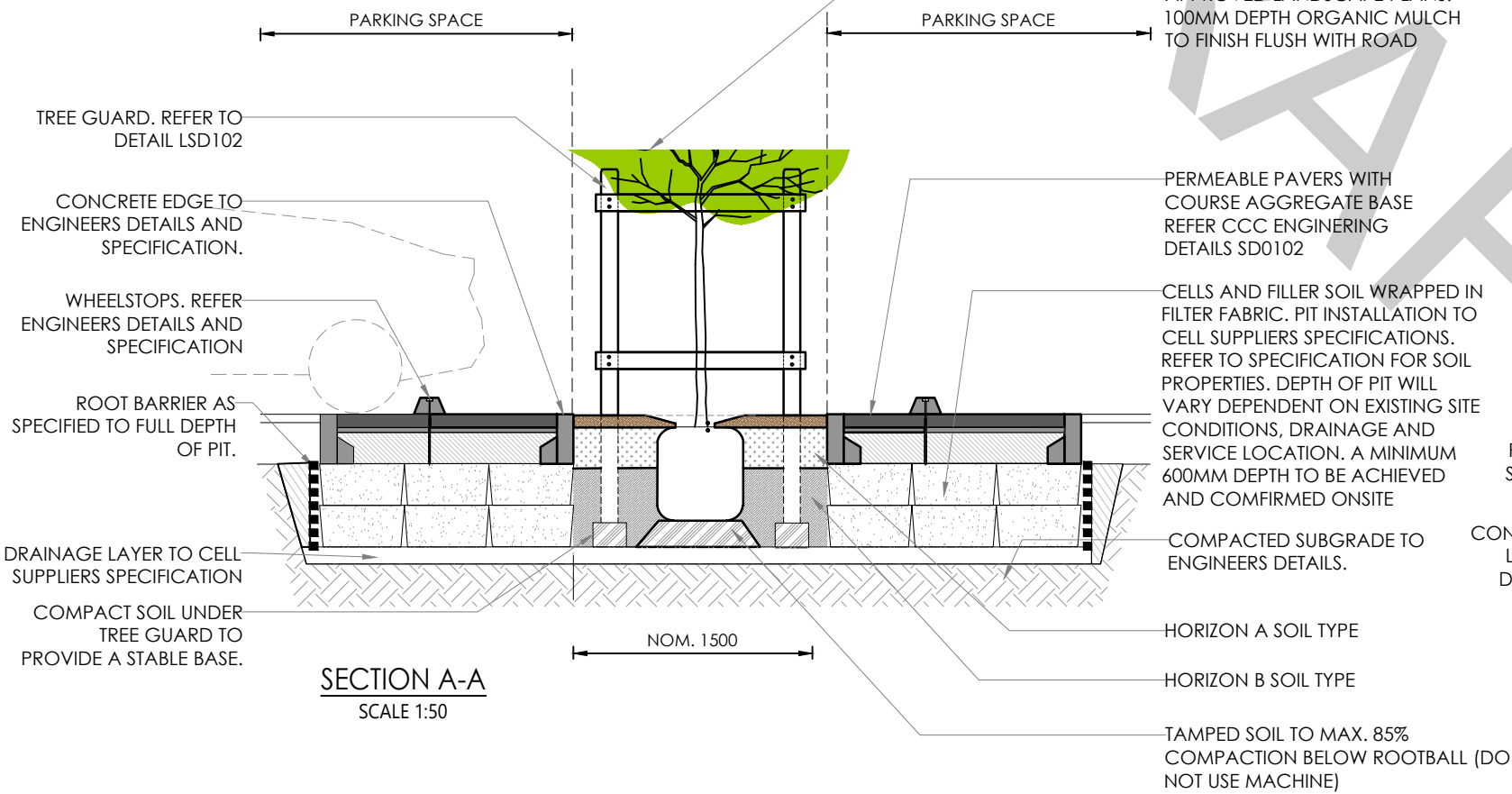

SECTION A-A
SCALE 1:50

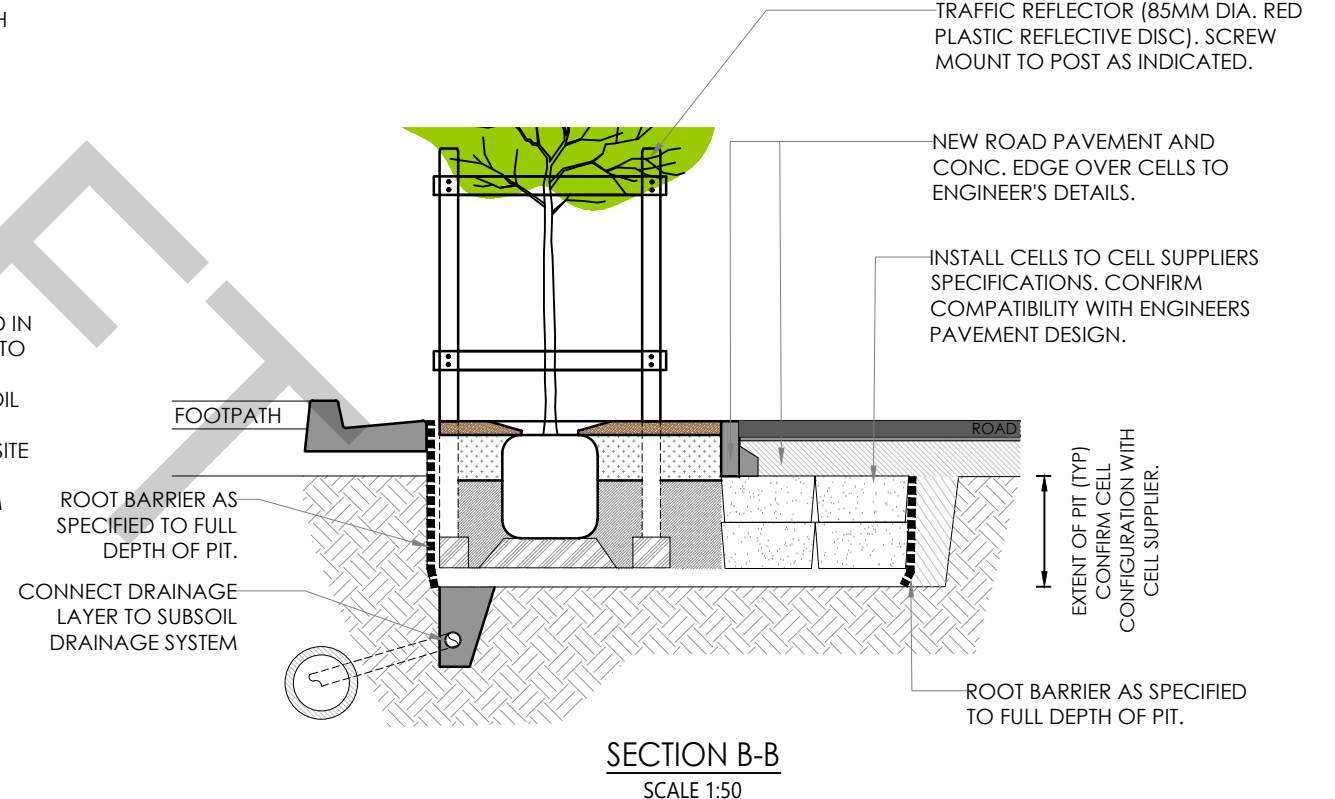

SECTION B-B
SCALE 1:50

					SCALE ON ORIGINAL A3 SIZE DRAWING	DRAWN	-		CENTRAL COAST COUNCIL		STANDARD DRAWING	
					AS SHOWN	CHECKED	-		TREE PLANTING SERIES STREET TREE IN ROAD FLUSH WITH ROAD LEVEL		DRAWING NUMBER	REV
						DATE	-				LSD104	A
						UNIT MANAGER APPROVAL						A3
REV	AMENDMENT	DATE	DRAWN	APRVD	ALL DIMENSIONS IN mm UNLESS OTHERWISE SHOWN	ASSETS PLANNING AND DESIGN						

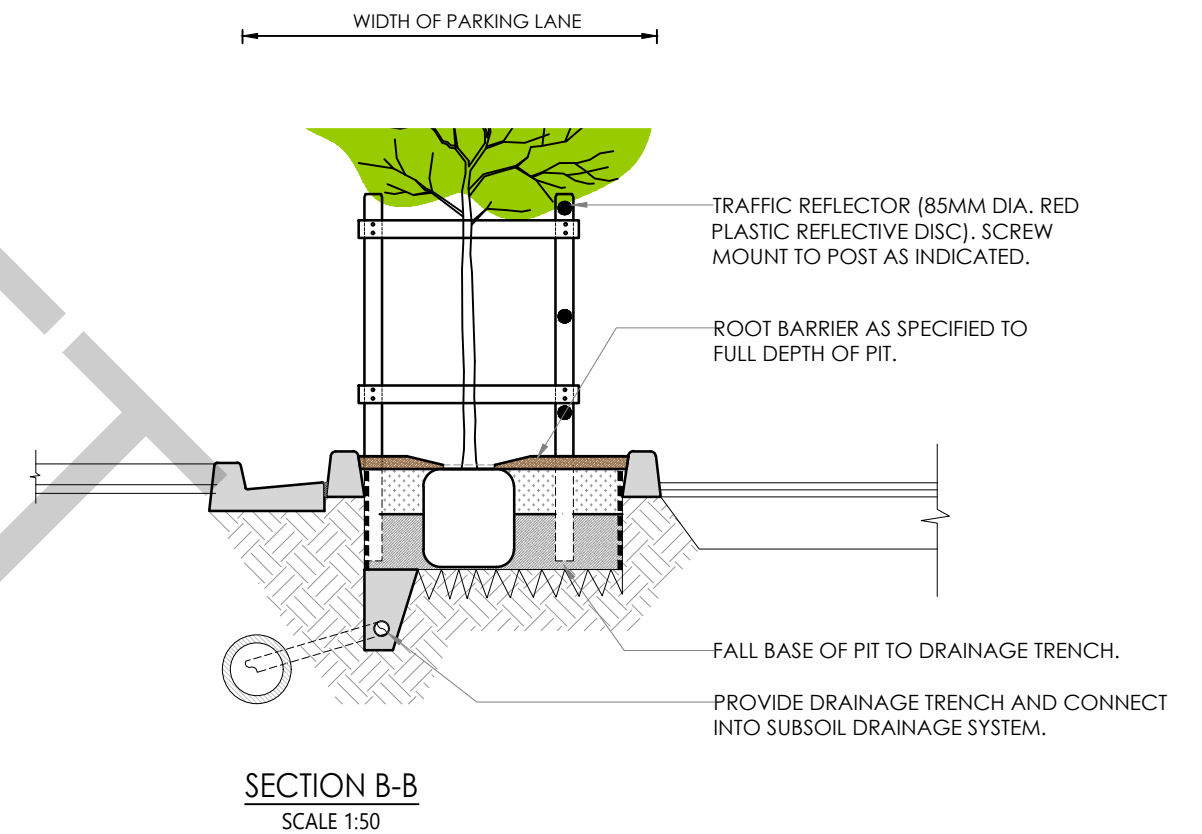
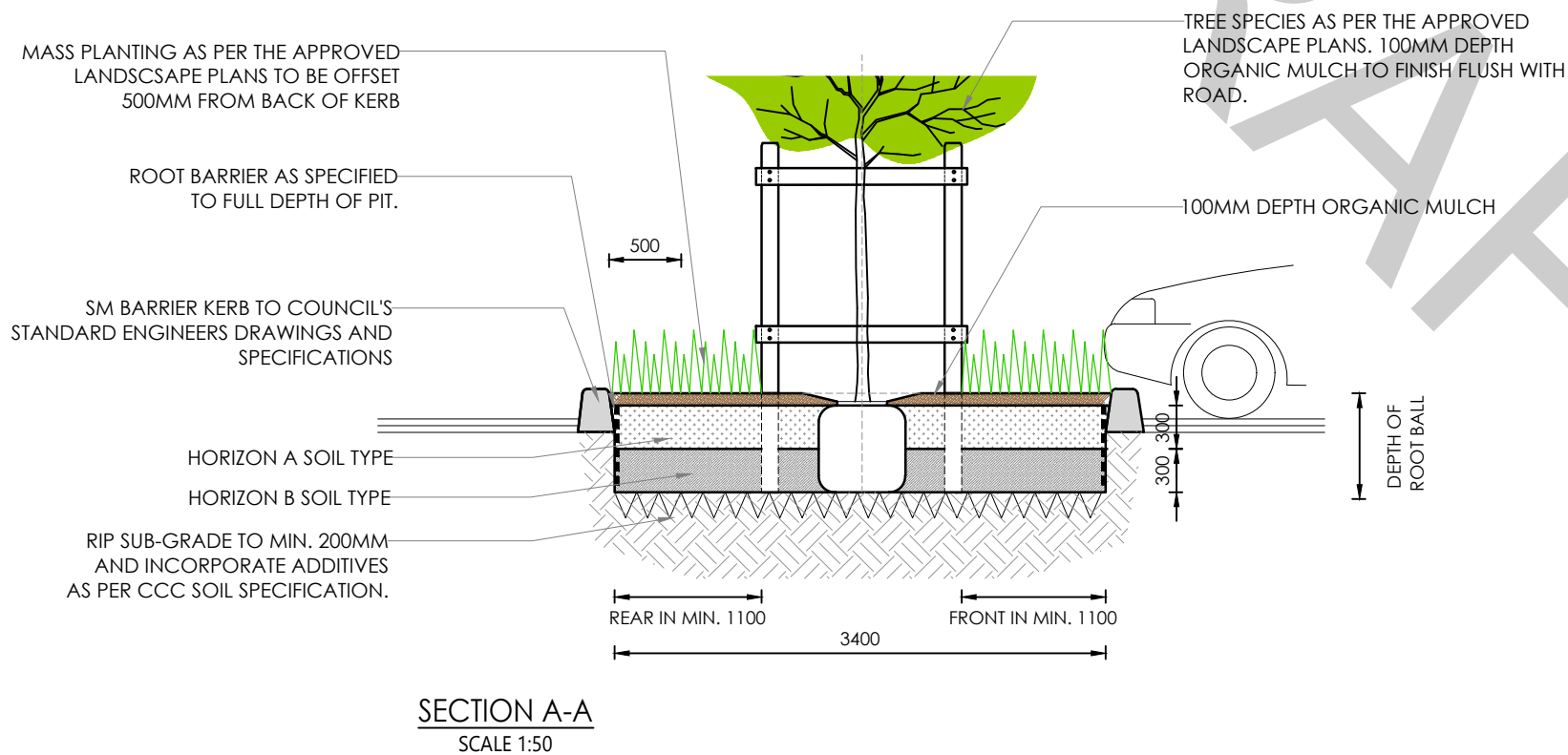
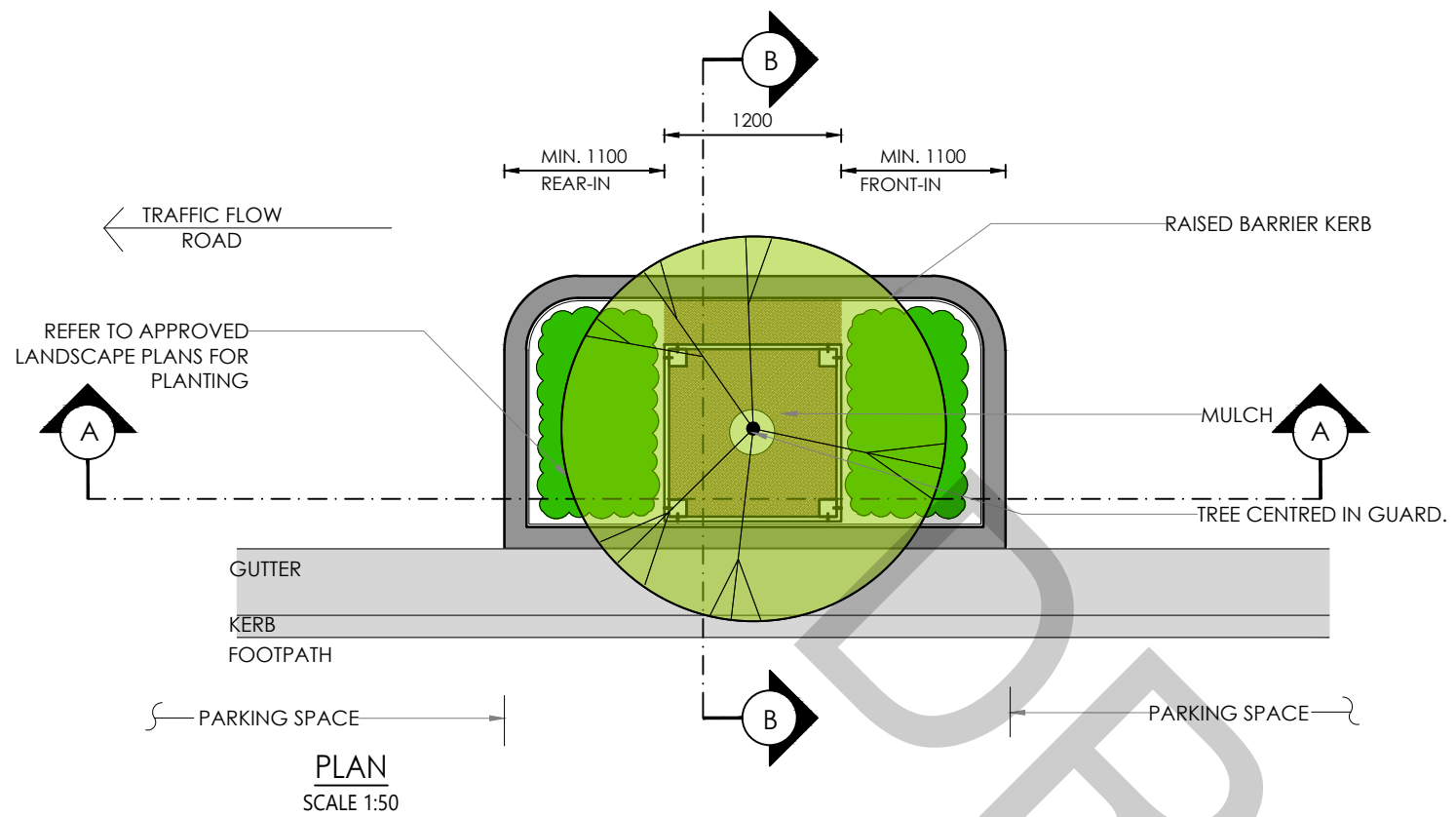

NOTES

1. TREE SUPPLY IN ACCORDANCE WITH AS2303. REFER TO CCC LANDSCAPE SPECIFICATION, SECTION 6 PLANT PROCUREMENT, FOR FURTHER DETAIL.
2. TREE SPECIES SUBSTITUTION REQUIRES WRITTEN CONSENT FROM CCC.
3. OBTAIN DBYD DRAWINGS PRIOR TO STARTING WORK.
4. GROUND TRUTH ALL POSSIBLE CONFLICTS WITH UNDERGROUND AND OVERHEAD SERVICES PRIOR TO COMMENCEMENT OF WORKS.
5. MINIMUM TREE INSTALLATION SIZE IS 75L UNLESS INDICATED IN CONDITIONS OF CONSENT.
6. CONFIRM COMPATIBILITY BETWEEN PIT DESIGN AND PAVEMENT DESIGN.
7. REFER TO CCC SOIL SPECIFICATION LSD801 FOR SOIL PROPERTIES.
8. REFER TO CCC LANDSCAPE SPECIFICATION LSD802 FOR ALL PROGRAMMING, PLANTING, ESTABLISHMENT AND MAINTENANCE OPERATIONS REQUIREMENTS.
9. CONFIRM LOCATIONS OF SUBSOIL DRAINAGE SYSTEM PRIOR TO COMMENCING TREE PIT WORKS. NOTIFY COUNCIL'S PROJECT OFFICER IF NO DRAINAGE SYSTEM IS AVAILABLE TO CONNECT INTO.

					SCALE ON ORIGINAL A3 SIZE DRAWING		DRAWN -				CENTRAL COAST COUNCIL		STANDARD DRAWING	
					0 500 1000 1500 2000 2500		CHECKED -						DRAWING NUMBER	
					1:50		DATE -				LSD105		A	
					ALL DIMENSIONS IN mm UNLESS OTHERWISE SHOWN		UNIT MANAGER APPROVAL		ASSETS PLANNING AND DESIGN		TREE PLANTING SERIES STREET TREE IN ROAD IN RAISED BLISTER		-	
REV					AMENDMENT		DATE						DRAWN	

ONE HARDWOOD STAKE 38 X 38 X 1500MM.
ENSURE STAKES DO NOT DAMAGE ROOTBALL
WHEN INSTALLED.

HESSIAN TIE TO FORM A LOOSE LOOP
AROUND TREE TRUNK. STAPLE TIE TO
HARDWOOD STAKE.

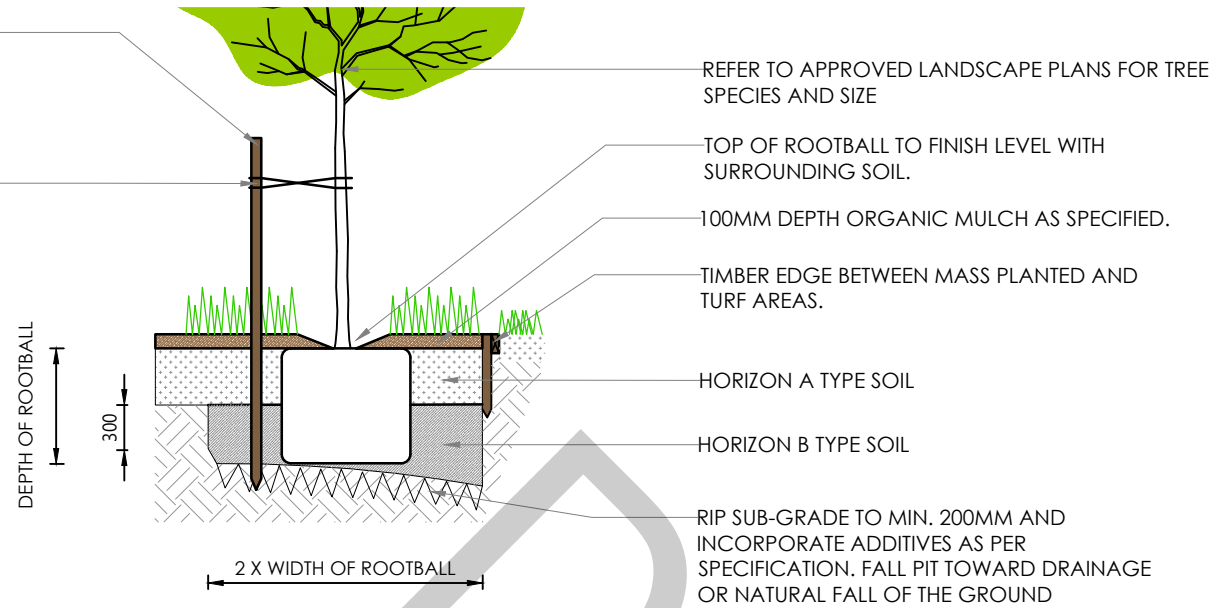

TREE IN PARK & RESERVE - MASS PLANTING (45L+)
SCALE 1:50

NOTES

1. OBTAIN DBYD DRAWINGS PRIOR TO STARTING WORK.
2. REMOVE STAKES AND TIES AT THE MID-POINT OF THE LANDSCAPE ESTABLISHMENT PERIOD, OR WHEN THE TREE IS SELF - SUPPORTING.
3. ALL TIMBER IN CONTACT WITH GROUND TO BE SUITABLE FOR IN-GROUND USE.
4. REFER TO CCC SOIL SPECIFICATION LSD801 FOR SOIL PROPERTIES.
5. REFER TO CCC LANDSCAPE SPECIFICATION LSD802 FOR ALL PROGRAMMING, PLANTING, ESTABLISHMENT AND MAINTENANCE OPERATIONS REQUIREMENTS.

ONE HARDWOOD STAKE 38 X 38 X 1500MM.
ENSURE STAKES DO NOT DAMAGE ROOTBALL
WHEN INSTALLED.

TOP OF ROOTBALL TO FINISH LEVEL WITH
SURROUNDING SOIL.

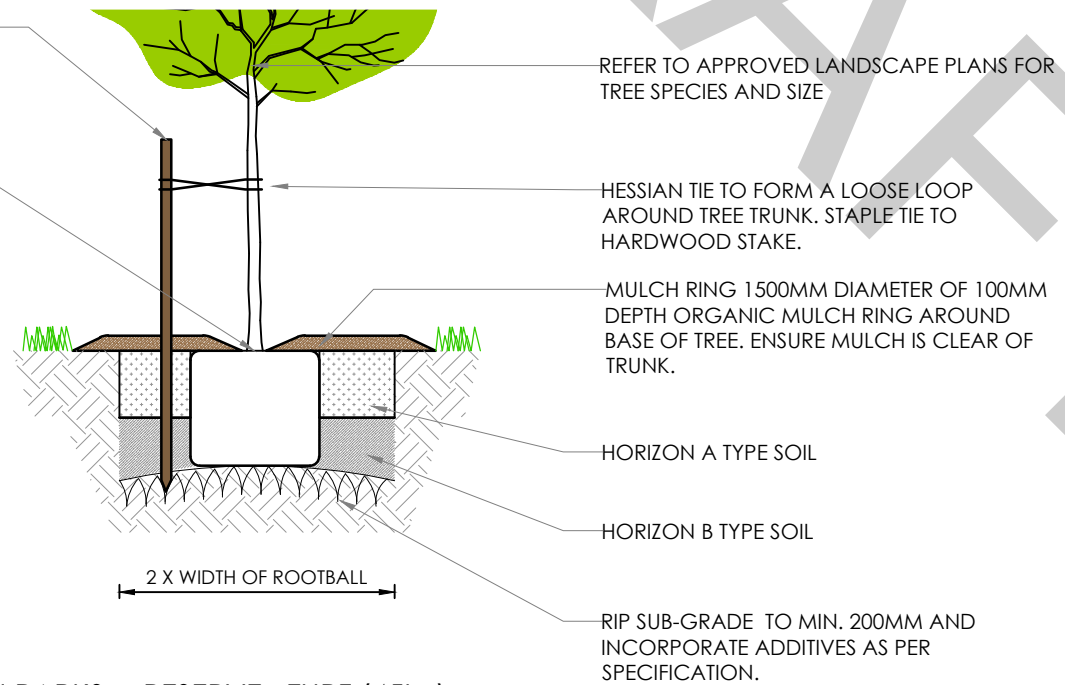

TREE IN PARKS & RESERVE - TURF (45L+)
SCALE 1:50

SCALE ON ORIGINAL A3 SIZE DRAWING

0 500 1000 1500 2000 2500



1:50

REV	AMENDMENT	DATE	DRAWN	APRVD
-----	-----------	------	-------	-------

ALL DIMENSIONS IN mm UNLESS OTHERWISE SHOWN

DRAWN	-
CHECKED	-
DATE	-
UNIT MANAGER APPROVAL	
ASSETS PLANNING AND DESIGN	



CENTRAL COAST COUNCIL

TREE PLANTING SERIES
TREES IN PARKS AND RESERVES

STANDARD DRAWING

DRAWING NUMBER	REV
LSD106	A
-	A3

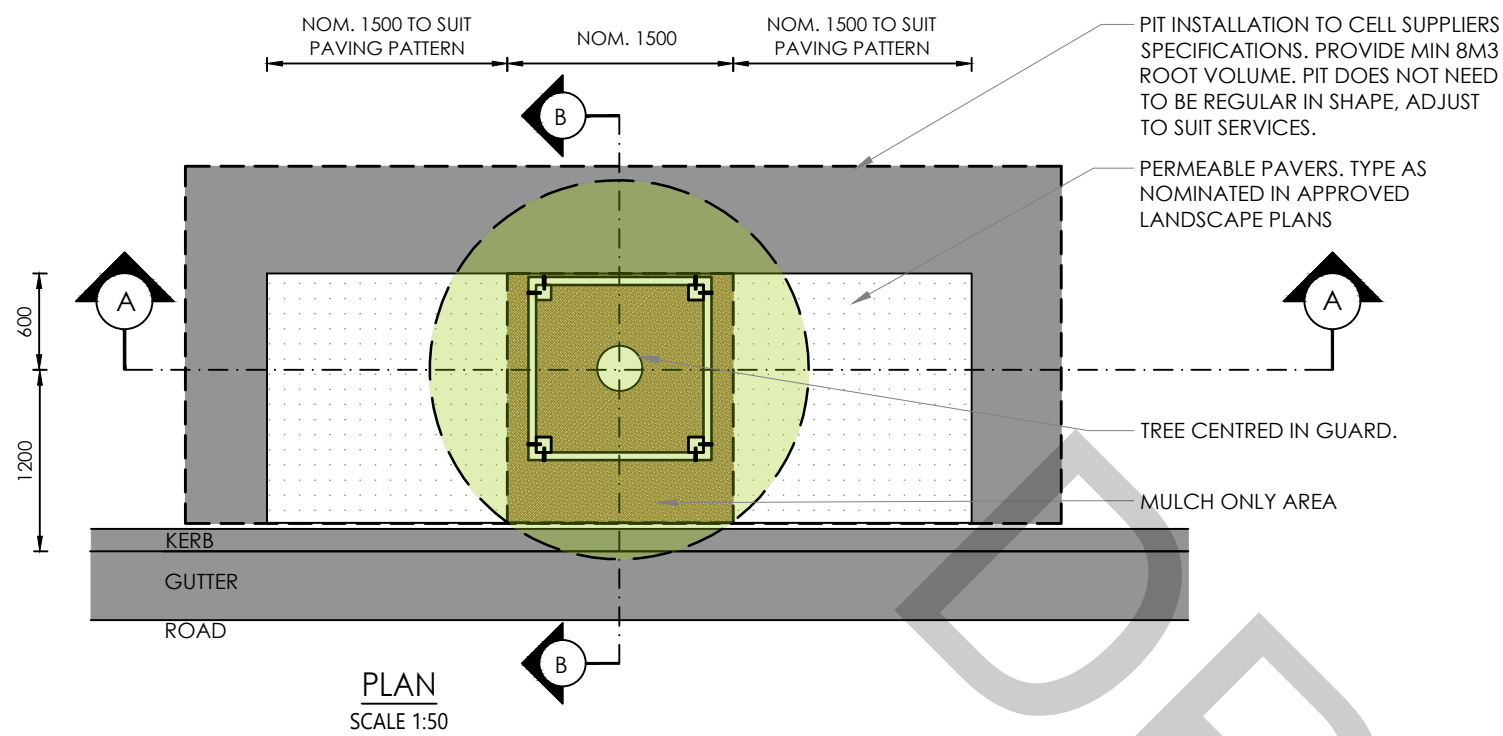

NOTES

1. TREE SUPPLY IN ACCORDANCE WITH AS2303. REFER TO CCC LANDSCAPE SPECIFICATION, SECTION 6 PLANT PROCUREMENT, FOR FURTHER DETAIL.
2. TREE SPECIES SUBSTITUTION REQUIRES WRITTEN CONSENT FROM CCC.
3. OBTAIN DBYD DRAWINGS PRIOR TO STARTING WORK.
4. GROUND TRUTH ALL POSSIBLE CONFLICTS WITH UNDERGROUND AND OVERHEAD SERVICES PRIOR TO COMMENCEMENT OF WORKS.
5. MINIMUM TREE INSTALLATION SIZE IS 75L UNLESS INDICATED IN CONDITIONS OF CONSENT.
6. CONFIRM COMPATIBILITY BETWEEN PIT DESIGN AND PAVEMENT DESIGN.
7. STRUCTURAL CELL PRODUCT MUST MEET COUNCILS REQUIREMENTS. THE STRUCTURAL CELL SYSTEM PROPOSED APPROVED BY COUNCIL'S PROJECT OFFICER PRIOR TO IMPLEMENTATION OF THE WORKS.
8. REFER TO CCC SOIL SPECIFICATION LSD801 FOR SOIL PROPERTIES.
9. REFER TO CCC LANDSCAPE SPECIFICATION LSD802 FOR ALL PROGRAMMING, PLANTING, ESTABLISHMENT AND MAINTENANCE OPERATIONS REQUIREMENTS.

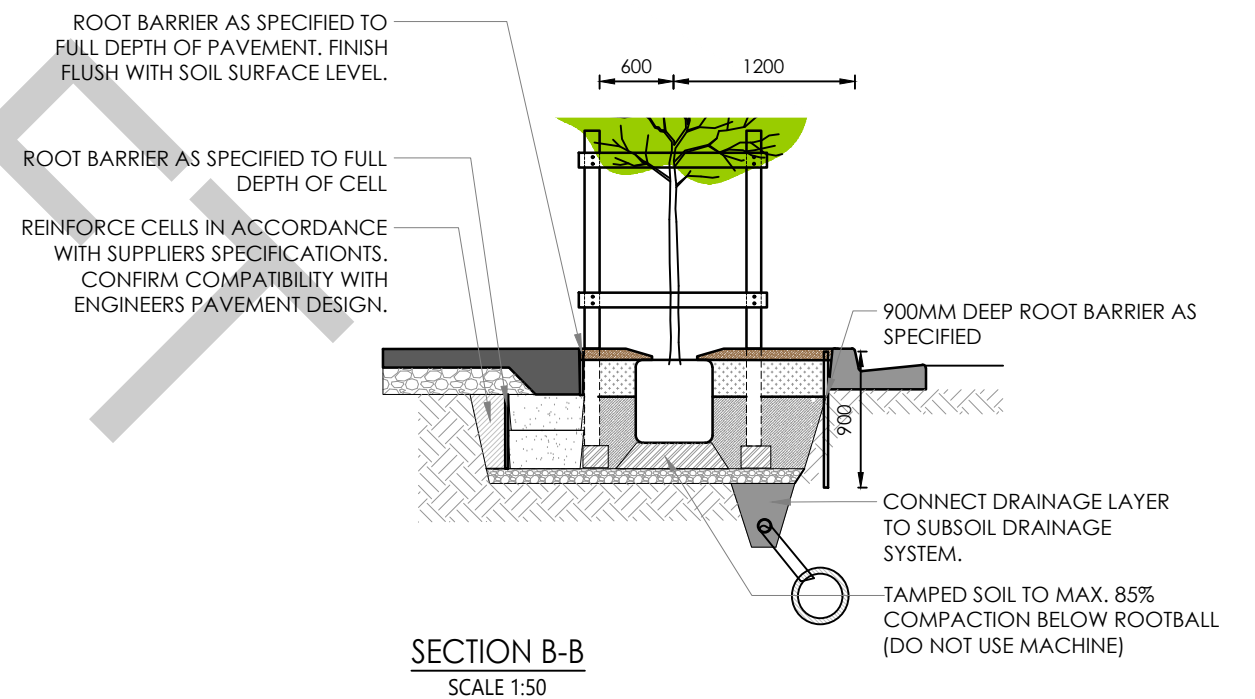
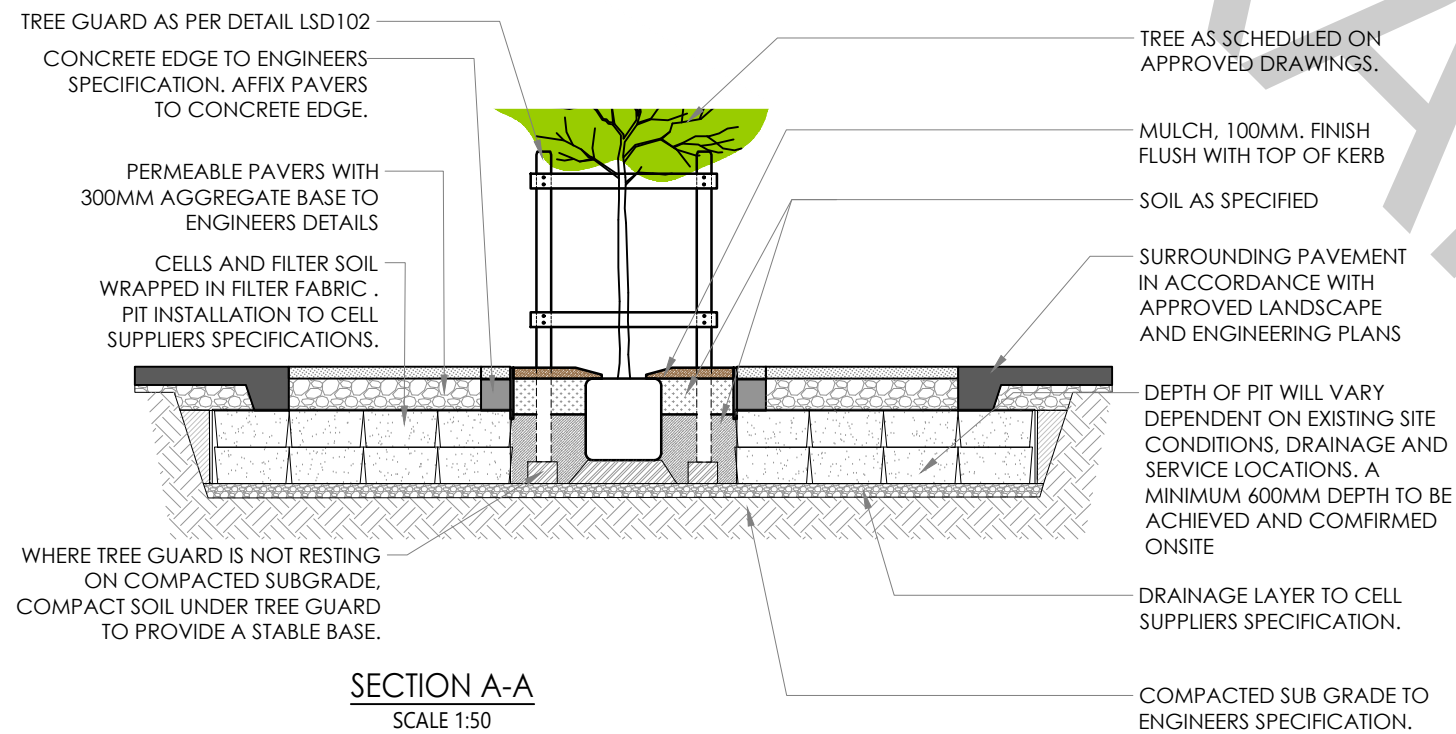

SCALE ON ORIGINAL A3 SIZE DRAWING					DRAWN	-		CENTRAL COAST COUNCIL		STANDARD DRAWING	
0 500 1000 1500 2000 2500					CHECKED	-				DRAWING NUMBER	REV
1:50					DATE	-		TREE PLANTING SERIES		LSD107	A
REV	AMENDMENT	DATE	DRAWN	APRVD	UNIT MANAGER APPROVAL			TREES IN PAVEMENT		-	A3
ALL DIMENSIONS IN mm UNLESS OTHERWISE SHOWN					ASSETS PLANNING AND DESIGN			© Central Coast Council 2022			

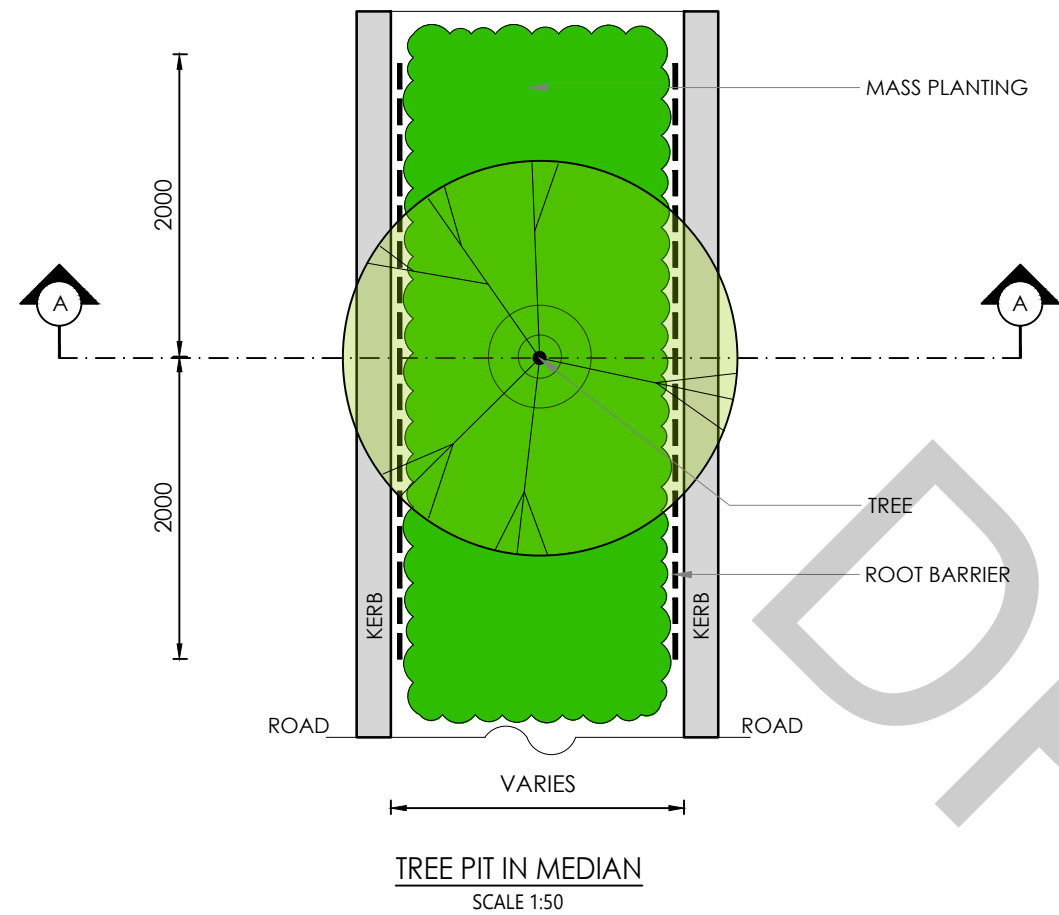

NOTES

1. COMPLY WITH ALL RELEVANT AUSTRALIAN STANDARDS AND TRANSPORT FOR NSW GUIDELINES.
2. OBTAIN DYBD DRAWINGS PRIOR TO STARTING WORK
3. GROUND TRUTH POSSIBLE CONFLICT WITH UNDERGROUND AND OVERHEAD SERVICE PRIOR TO COMMENCEMENT OF WORKS.
4. CONFIRM LOCATIONS OF SUBSOIL DRAINAGE SYSTEM PRIOR TO COMMENCING TREE PIT WORKS. NOTIFY COUNCIL'S PROJECT OFFICER IF NO DRAINAGE SYSTEM IS AVAILABLE TO CONNECT INTO.
5. REFER TO CCC SOIL SPECIFICATION LSD801 FOR SOIL PROPERTIES.
6. REFER TO CCC LANDSCAPE SPECIFICATION LSD802 FOR ALL PROGRAMMING, PLANTING, ESTABLISHMENT AND MAINTENANCE OPERATIONS REQUIREMENT.
7. MINIMUM TREE INSTALLATION SIZE IS 75L UNLESS OTHERWISE INDICATED IN CONDITIONS OF CONSENT.
8. TREE SPECIES SUBSTITUTION REQUIRES WRITTEN CONSENT FROM CCC.
9. MINIMUM WIDTH OF MEDIAN TO BE 2000MM FOR TREE PLANTING. TREE PLANTING IN MEDIAN TO BE APPROVED BY COUNCIL.

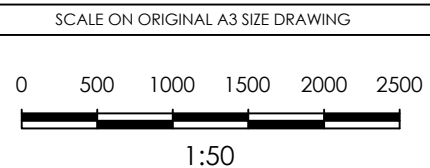
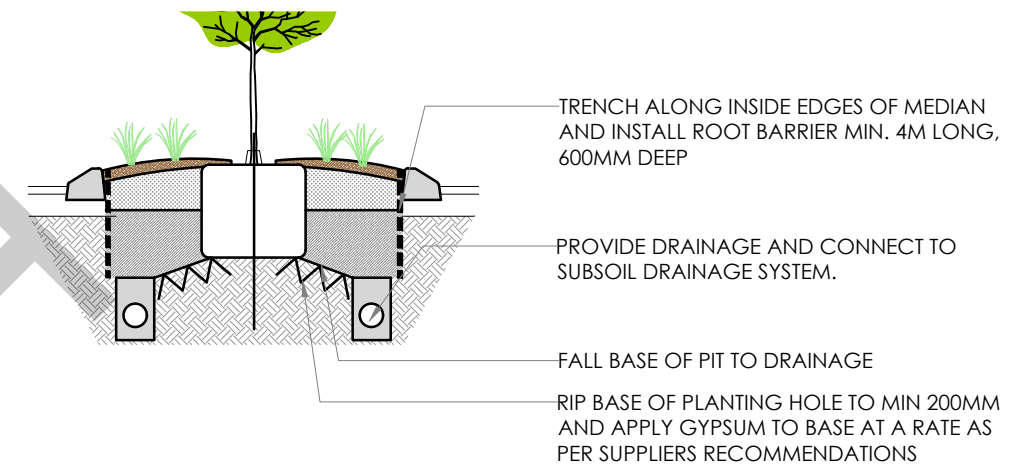
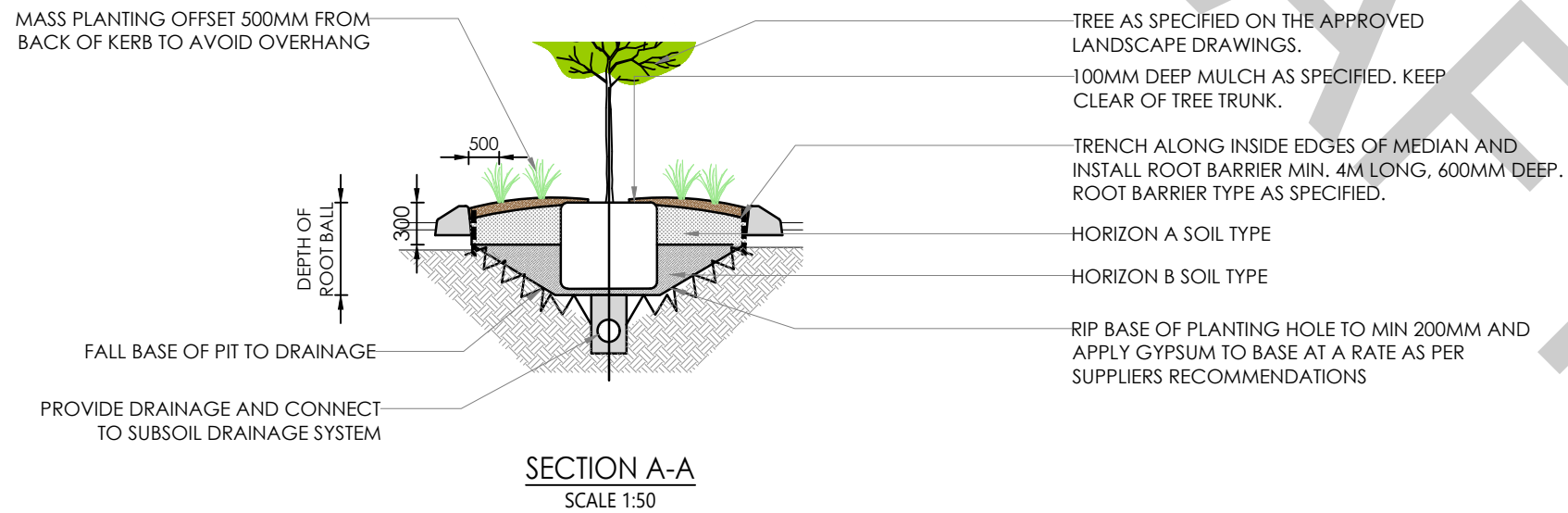

DRAWN	-
CHECKED	-
DATE	-
UNIT MANAGER APPROVAL	
ASSETS PLANNING AND DESIGN	



CENTRAL COAST COUNCIL

TREE PLANTING SERIES
TREES IN ROAD MEDIAN

STANDARD DRAWING	
DRAWING NUMBER	REV
LSD108	A
-	A3

REV	AMENDMENT	DATE	DRAWN	APRVD	ALL DIMENSIONS IN mm UNLESS OTHERWISE SHOWN

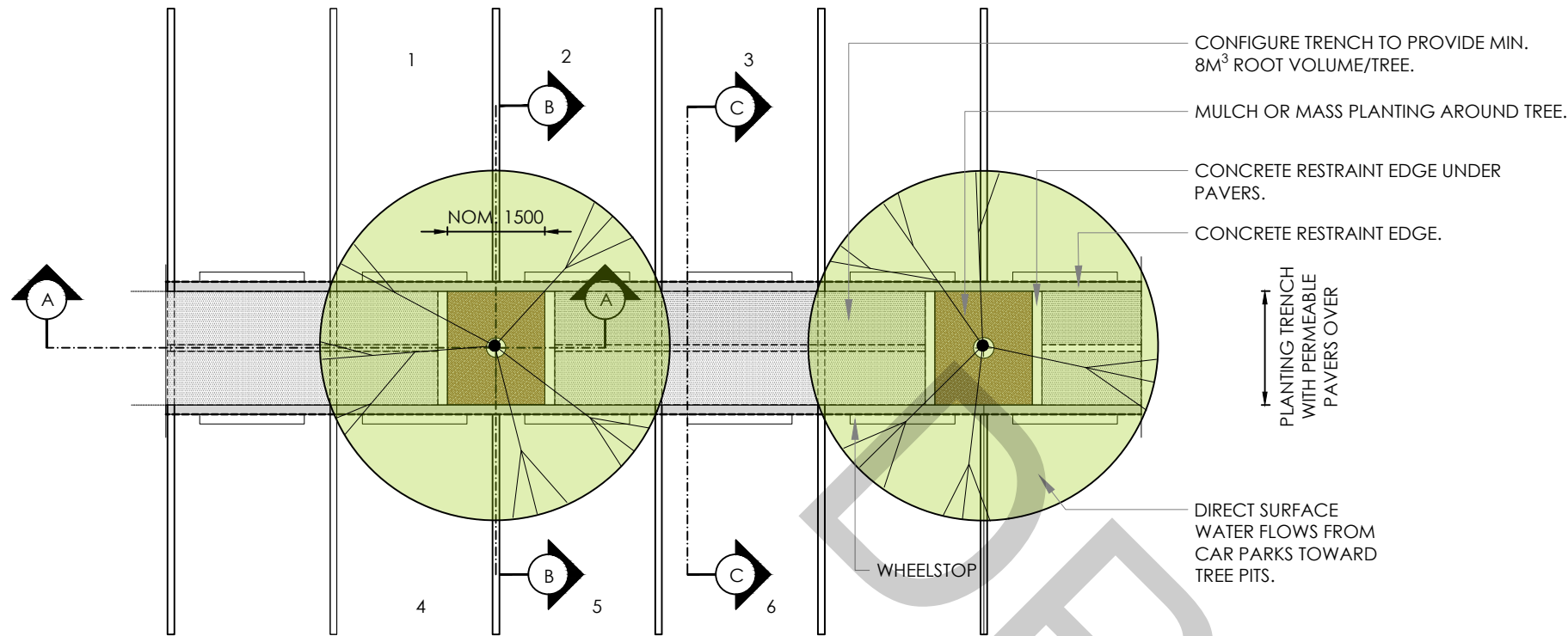

CENTRAL PLANTING TRENCH WITH STRUCTURAL CELLS
SCALE 1:100

NOTES

1. CONFIGURE PLANTING PITS TO PROVIDE A MINIMUM OF 8M³ SOIL VOLUME PER TREE.
2. STRUCTURAL CELL SYSTEM PROPOSED FOR USE MUST BE APPROVED BY COUNCIL'S PROJECT OFFICER.
3. OBTAIN DBYD DRAWING PRIOR TO STARTING WORK.
4. GROUND TRUTH ALL POSSIBLE CONFLICTS WITH UNDERGROUND AND OVERHEAD SERVICE PRIOR TO COMMENCEMENT OF WORKS.
5. MINIMUM TREE INSTALLATION SIZE IS 75L UNLESS INDICATED OTHERWISE IN CONDITIONS OF CONSENT.
6. TREE SPECIES SUBSTITUTION REQUIRES WRITTEN CONSENT FROM CCC.
7. REFER TO CCC SOIL SPECIFICATION LSD801 FOR SOIL PROPERTIES.
8. REFER TO CCC LANDSCAPE SPECIFICATION LSD802 FOR ALL PROGRAMMING, PLANTING, ESTABLISHMENT AND MAINTENANCE OPERATIONS REQUIREMENTS.

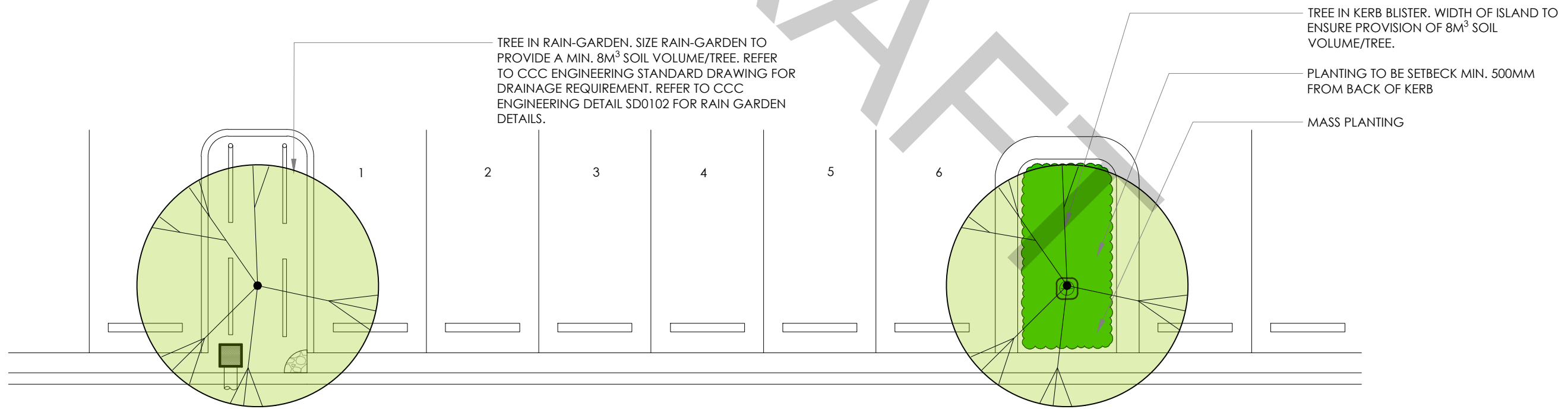

PLANTING IN KERB BLISTER - RAIN GARDEN AND STANDARD OPTIONS
SCALE 1:100

SCALE ON ORIGINAL A3 SIZE DRAWING

0 500 1000 1500 2000 2500



1:50

REV	AMENDMENT	DATE	DRAWN	APRVD

ALL DIMENSIONS IN mm UNLESS OTHERWISE SHOWN

DRAWN	-
CHECKED	-
DATE	-
UNIT MANAGER APPROVAL	
ASSETS PLANNING AND DESIGN	



CENTRAL COAST COUNCIL

TREE PLANTING SERIES
TREES IN CAR PARK-
SHEET 1

STANDARD DRAWING

DRAWING NUMBER	REV
LSD109	A
-	A3

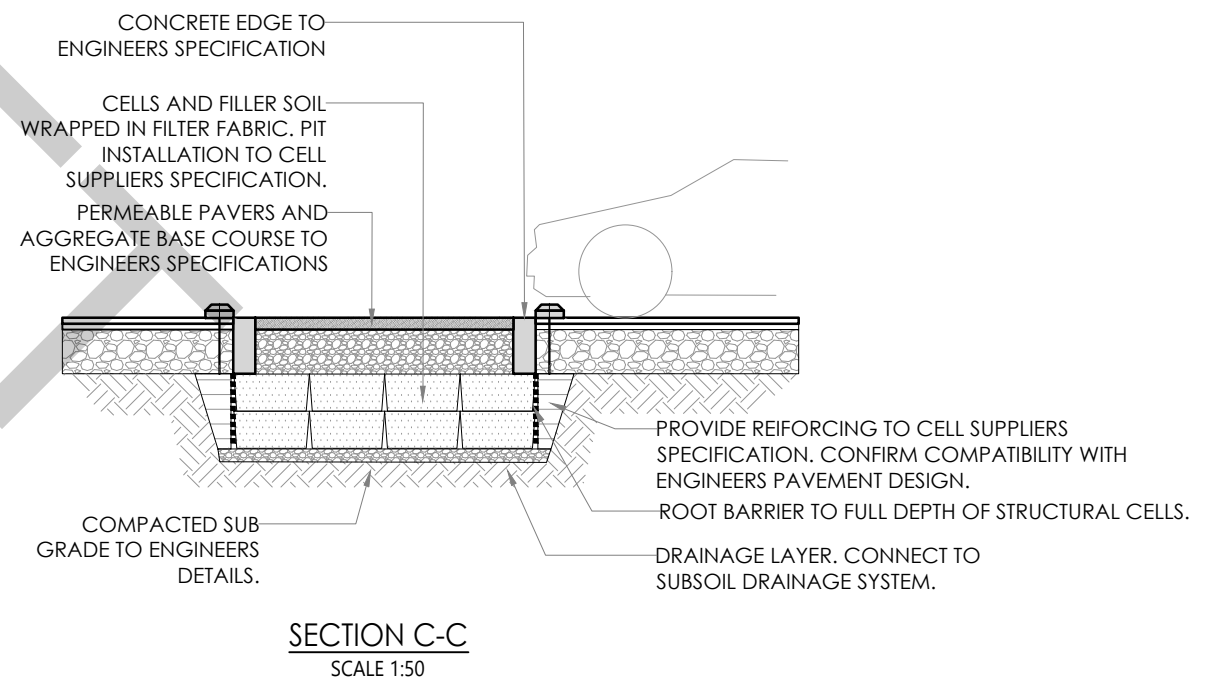
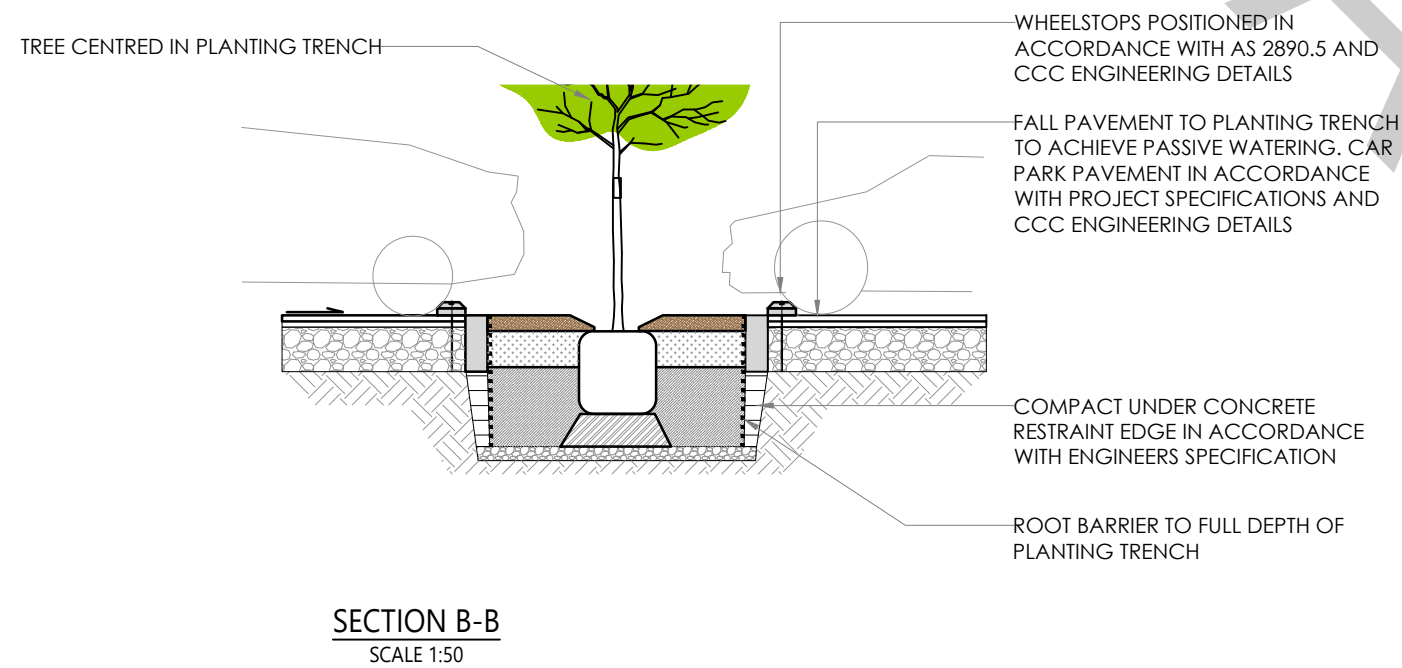
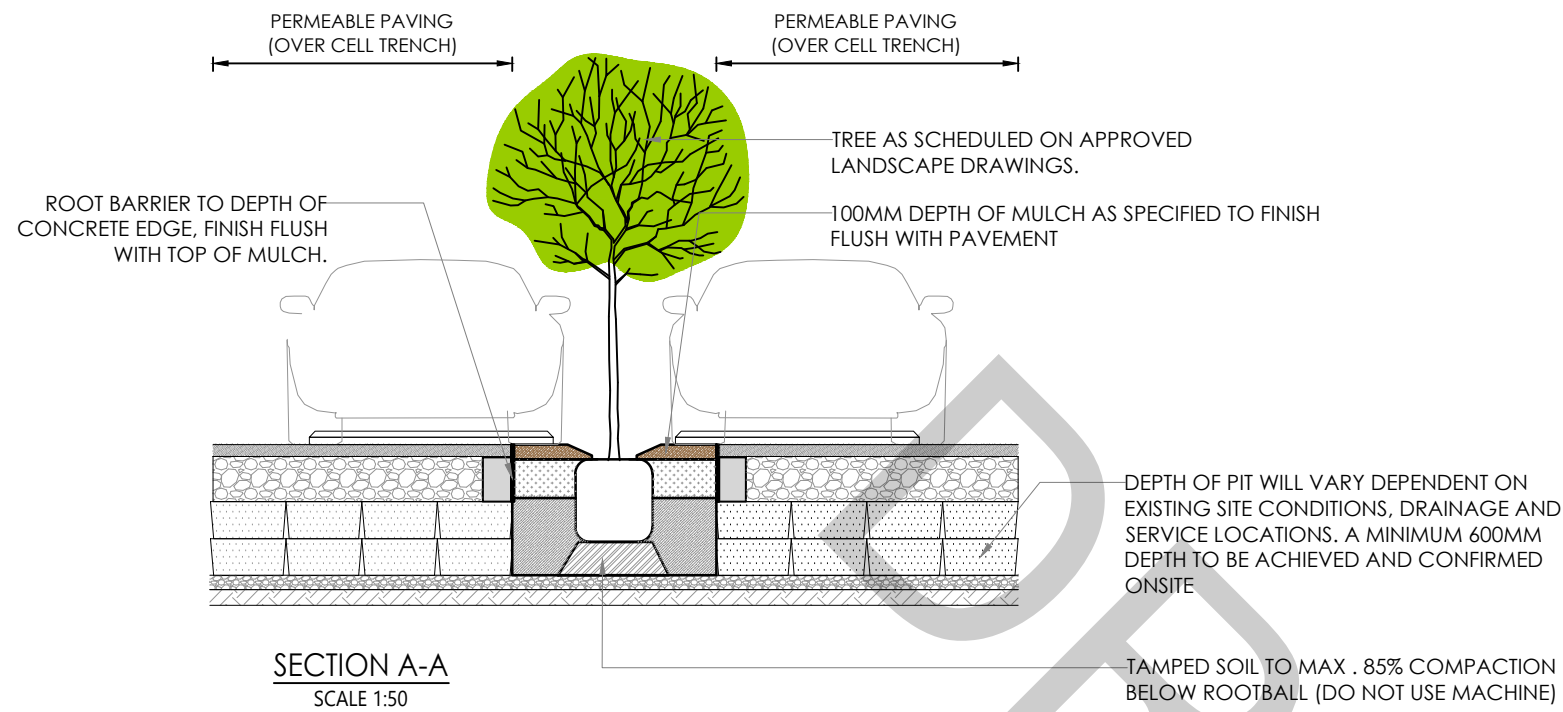

SCALE ON ORIGINAL A3 SIZE DRAWING

0 500 1000 1500 2000 2500



1:50

ALL DIMENSIONS IN mm UNLESS OTHERWISE SHOWN

DRAWN -
CHECKED -
DATE -

UNIT MANAGER APPROVAL

ASSETS PLANNING AND DESIGN



CENTRAL COAST COUNCIL

TREE PLANTING SERIES
TREES IN CAR PARK -
SHEET 2

STANDARD DRAWING

DRAWING NUMBER REV

LSD110 A

- A3

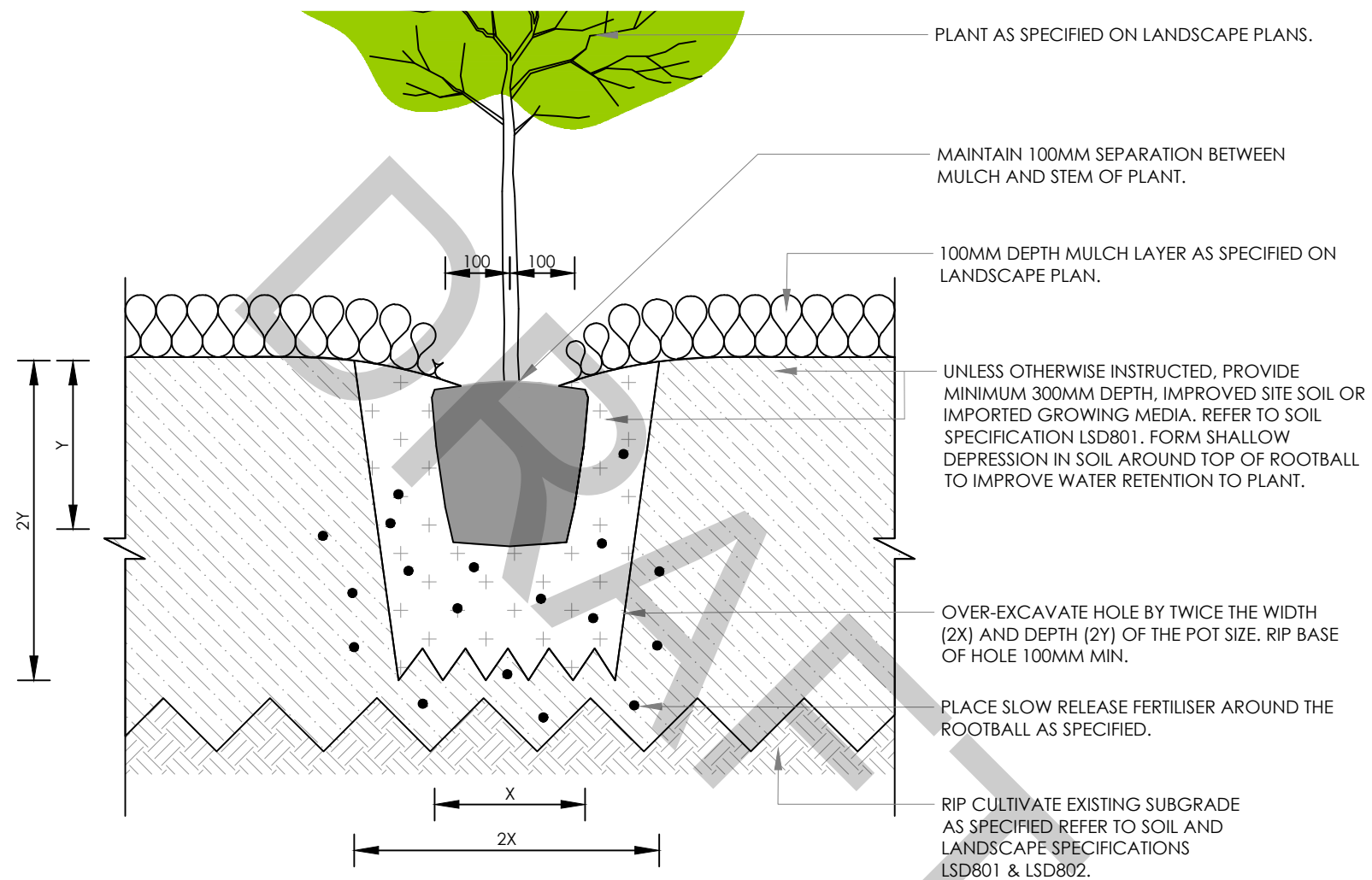

TYPICAL SHRUB / GROUNDCOVER PLANT - SECTION
SCALE 1:10

R

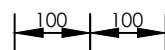

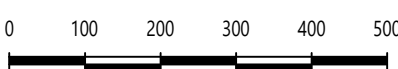
REV	AMENDMENT	DATE	DRAWN	APRVD	SCALE ON ORIGINAL A3 SIZE DRAWING	DRAWN	-		CENTRAL COAST COUNCIL	STANDARD DRAWING	
					 1:10 ALL DIMENSIONS IN mm UNLESS OTHERWISE SHOWN	CHECKED	-			DRAWING NUMBER	REV
						UNIT MANAGER APPROVAL			GENERAL PLANTING SERIES MASS PLANTING IN GARDEN BED	LSD201	A
						ASSETS PLANNING AND DESIGN				-	A3

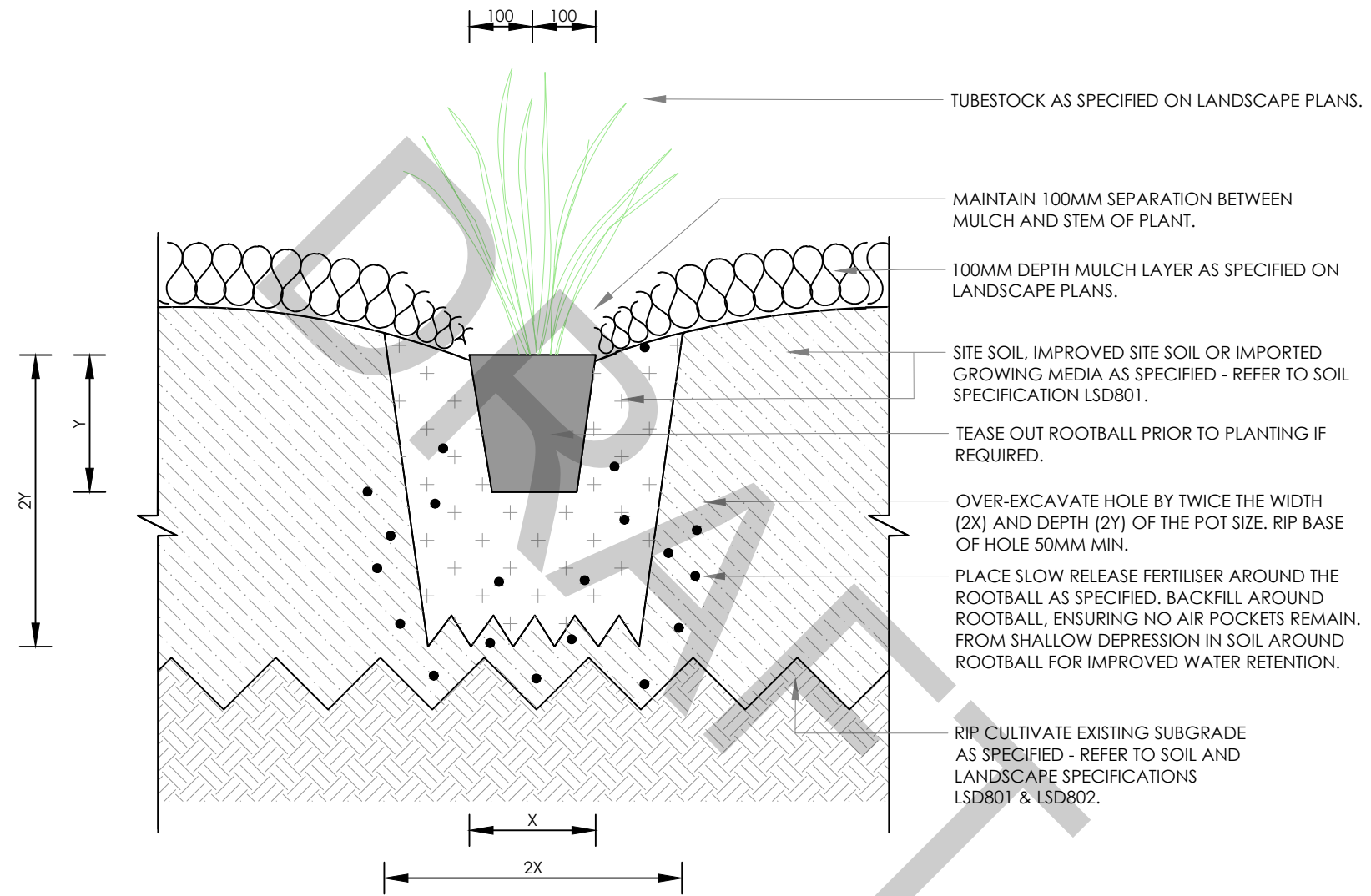

TYPICAL TUBESTOCK PLANT - SECTION
SCALE 1:10

SCALE ON ORIGINAL A3 SIZE DRAWING

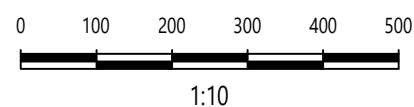

ALL DIMENSIONS IN mm UNLESS OTHERWISE SHOWN

DRAWN	-
CHECKED	-
DATE	-
UNIT MANAGER APPROVAL	
ASSETS PLANNING AND DESIGN	



CENTRAL COAST COUNCIL

GENERAL PLANTING SERIES
TUBESTOCK PLANTING

STANDARD DRAWING

DRAWING NUMBER	REV
LSD202	A
-	A3

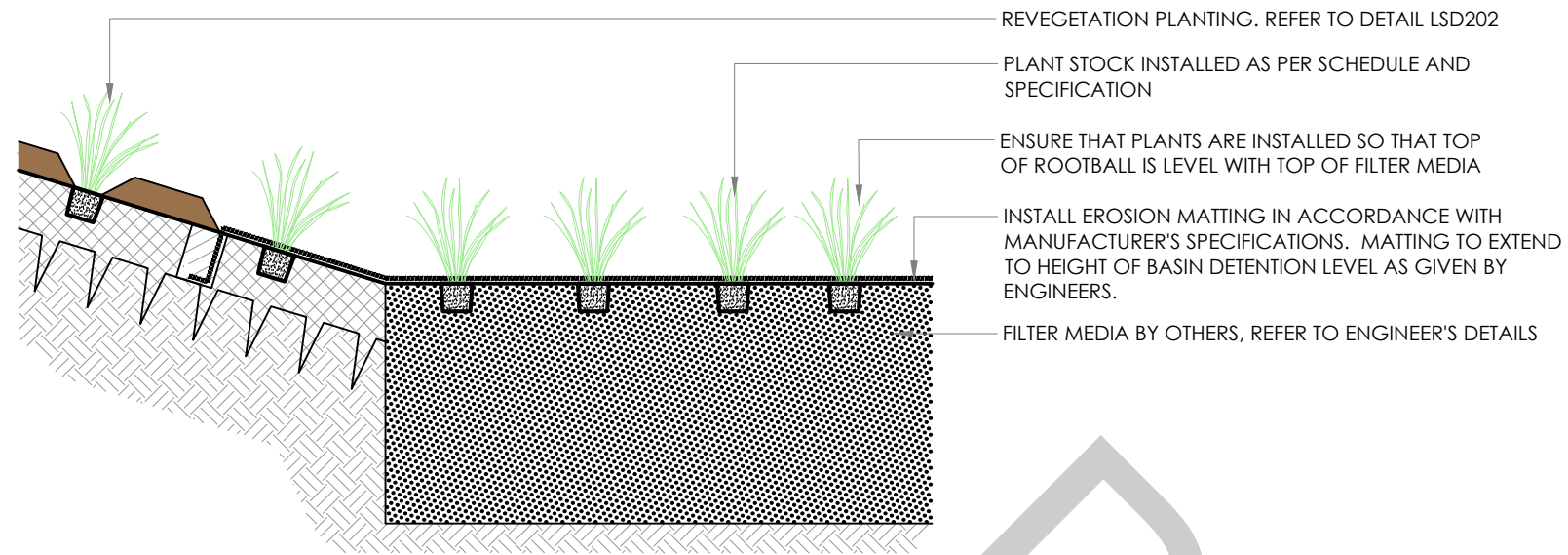

BATTER PLANTING/ BASIN FLOOR - TYPICAL DETAIL
SCALE 1:20

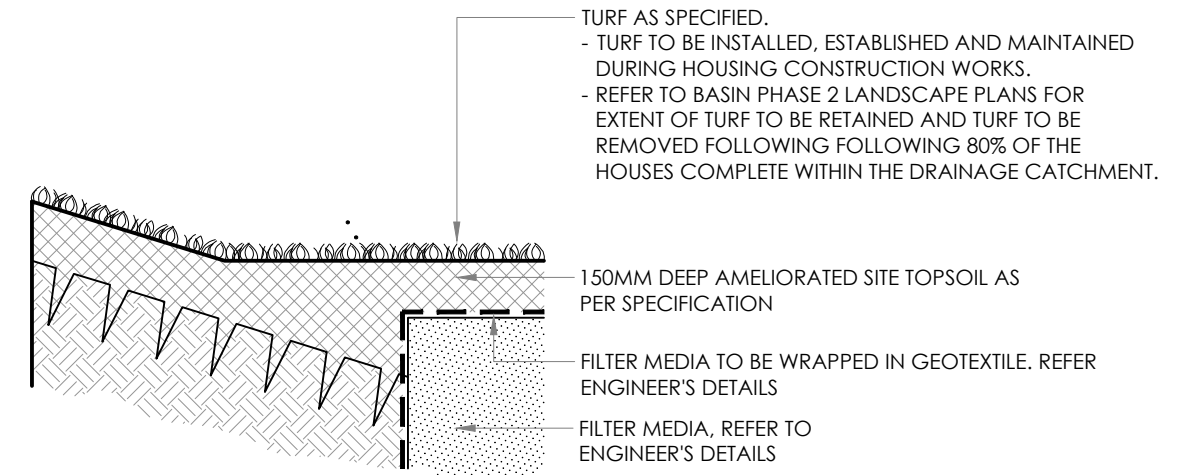

BASIN TEMPORARY TURF - TYPICAL DETAIL
SCALE 1:20

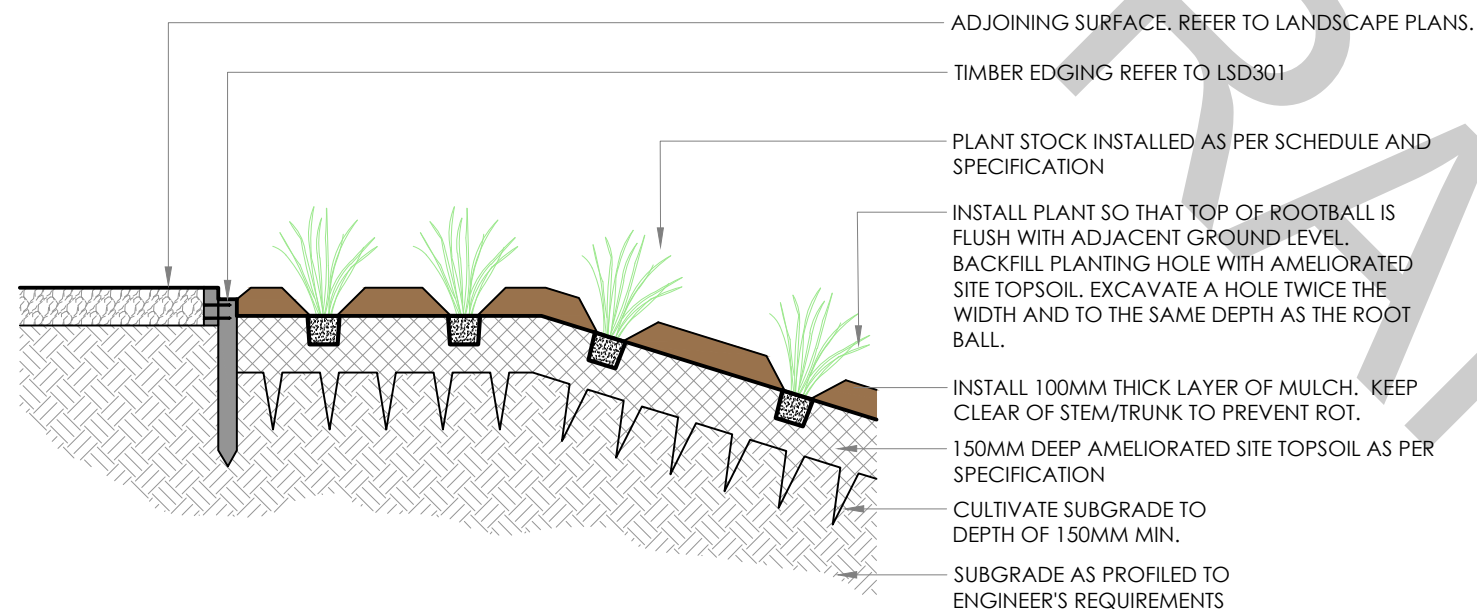

BASIN BATTER PLANTING - TYPICAL DETAIL
SCALE 1:20

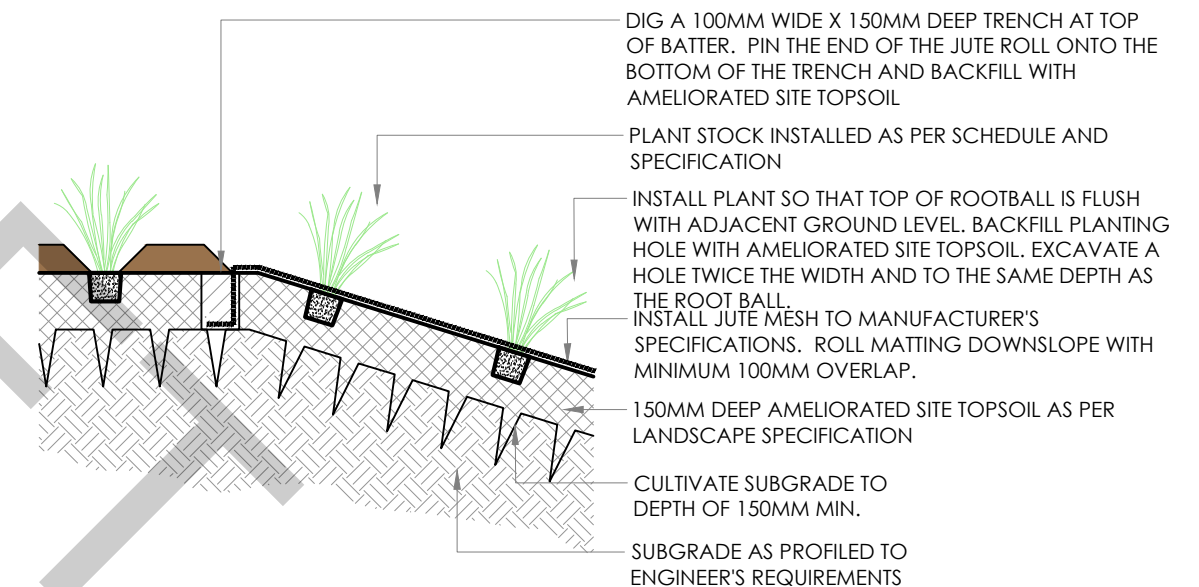

JUTE PLANTING - TYPICAL DETAIL
SCALE 1:20

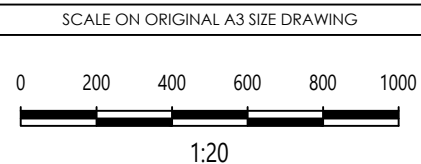

REV	AMENDMENT	DATE	DRAWN	APRVD

DRAWN	-
CHECKED	-
DATE	-
UNIT MANAGER APPROVAL	
ASSETS PLANNING AND DESIGN	



CENTRAL COAST COUNCIL	
GENERAL PLANTING SERIES BIORETENTION BASIN PLANTING	

STANDARD DRAWING	
DRAWING NUMBER	REV
LSD203	A
-	A3

TURF AS SCHEDULED ON APPROVED LANDSCAPE PLANS. LAY TURF IN STRETCHER PATTERN WITH JOINTS STAGGERED AND CLOSE BUTTED. TURF REQUIREMENTS IN ACCORDANCE WITH LANDSCAPE SPECIFICATION LSD802.

TOP SOIL IN ACCORDANCE WITH SOIL SPECIFICATION LSD801.

SUBGRADE. REMOVE RUBBISH, WEEDS AND OTHER DELETERIOUS MATERIALS. REMOVE STONES AND CLOUDS EXCEEDING 50MM.

CULTIVATE SUBGRADE TO NOM. 100MM DEEP AT 600MM CENTRES, PARALLEL TO CONTOURS. INCORPORATE SUBSOIL ADDITIVES IN ACCORDANCE WITH SOIL SPECIFICATION LSD801.

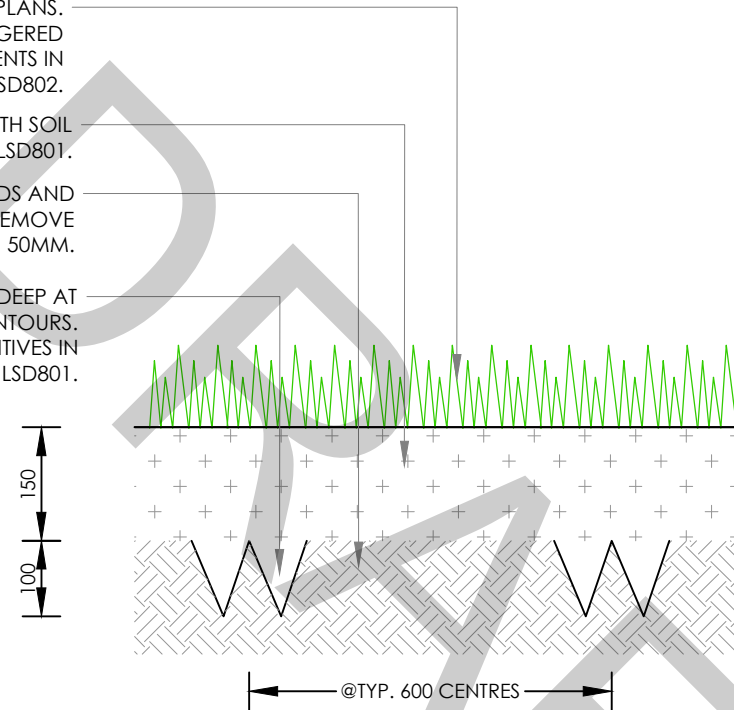

TYPICAL TURF PLANTING
SCALE 1:10

NOTES

1. THIS DETAIL IS NOT INTENDED FOR SPORTS FIELDS. SPECIALIST SPORTS TURF ADVICE IS REQUIRED FOR PLAYING SURFACES.
2. TURF SPECIES TO BE COUCH UNLESS OTHERWISE INDICATED IN CONDITIONS OF CONSENT.

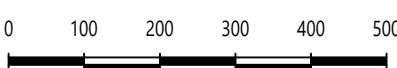
REV	AMENDMENT	DATE	DRAWN	APRVD	SCALE ON ORIGINAL A3 SIZE DRAWING		DRAWN	-		CENTRAL COAST COUNCIL		STANDARD DRAWING	
					 1:10		CHECKED	-		GENERAL PLANTING SERIES		DRAWING NUMBER	REV
ALL DIMENSIONS IN mm UNLESS OTHERWISE SHOWN		UNIT MANAGER APPROVAL		-		TURF		LSD204		A			
					ASSETS PLANNING AND DESIGN		-			A3			

- H4 TREATED TIMBER PEGS:**
- NOM. 50MM SQUARE PEGS X 450MM LONG, SHARPENED AT ONE END AND DRIVEN INTO FIRM GROUND;
 - GENERALLY PLACE PEGS ON THE MASS PLANTING SIDE AT 1200MM CENTRES, AT CHANGES IN DIRECTION & AT EACH END OF TIMBER EDGE BOARDS;
 - FINISH 25MM BELOW EDGE BOARDS. DRIVE IN ON PLANTING SIDE OF EDGING.

- TIMBER EDGE BOARD:**
- NOM. 38 X 100MM (NOM. 2400MM LONG)
 - SAWN TIMBER, HAZARD CLASS H4 TO AS1604.
 - SECURED TO PEG WITH 2 GALVANISED NAILS PER PEG.

MAKE GOOD TURF IF DAMAGED DURING CONSTRUCTION.

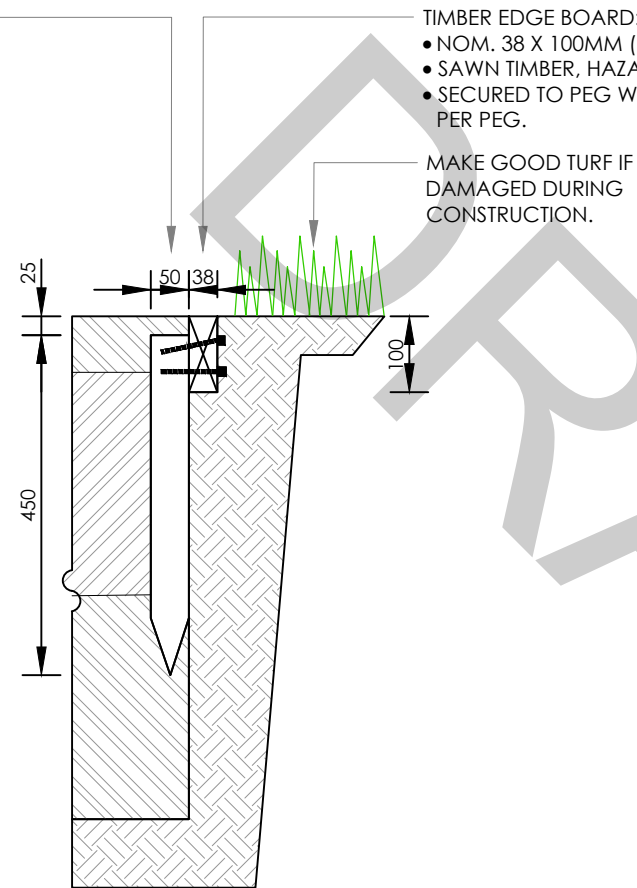

TYPICAL TIMBER EDGE
SCALE 1:10

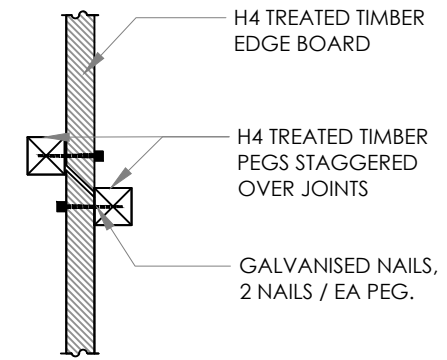

STRAIGHT TIMBER EDGING JOINT
SCALE 1:10

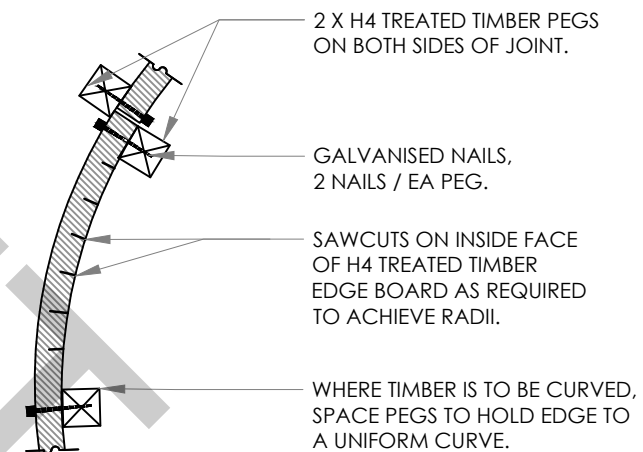

CURVED TIMBER EDGING JOINT
SCALE 1:10

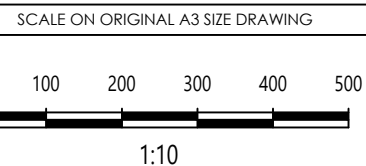

DRAWN	-
CHECKED	-
DATE	-
UNIT MANAGER APPROVAL	
ASSETS PLANNING AND DESIGN	



CENTRAL COAST COUNCIL

EDGING SERIES
TIMBER GARDEN EDGE

STANDARD DRAWING

DRAWING NUMBER	REV
LSD301	A
-	A3

REV	AMENDMENT	DATE	DRAWN	APRVD
-----	-----------	------	-------	-------

ALL DIMENSIONS IN mm UNLESS OTHERWISE SHOWN

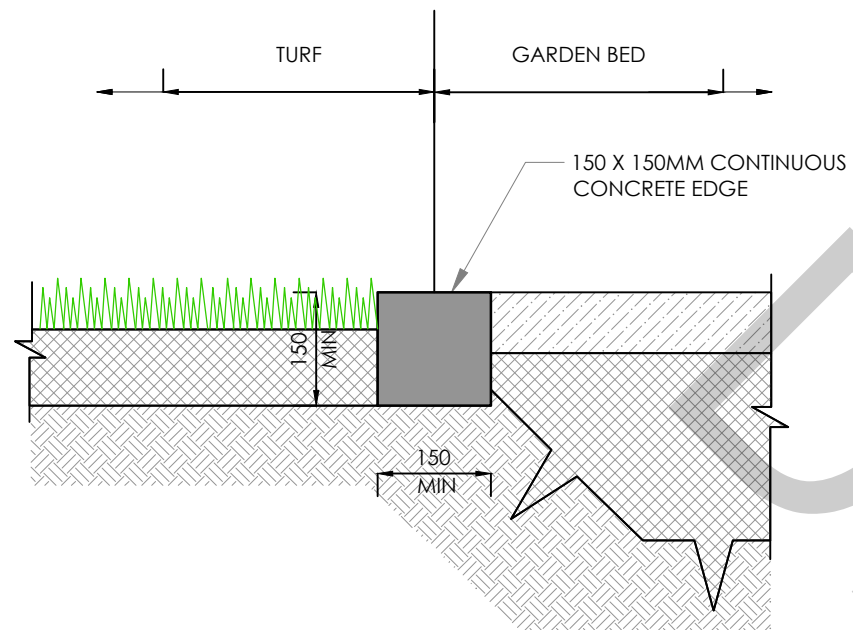

SECTION . CONCRETE EDGING - LEVEL EDGE
SCALE 1:10

NOTES



GENERAL NOTES

1. ENSURE MOWN HEIGHT OF GRASS (TURF) AREAS FINISH FLUSH WITH EDGING.
2. ENSURE GARDEN AREAS (MULCH) FINISH FLUSH WITH ADJACENT FINISH SURFACE LEVELS OF GARDEN EDGING.

CONCRETE NOTES

1. ALL MACHINE PLACED (EXTRUDED) CONCRETE TO BE GRADE S32. INSTALL CONTRACTION JOINTS AT 4M INTERVALS BY FORMING GROOVES 40MM DEEP BY 6MM WIDE TO ALL EXPOSED SURFACES NORMAL TO THE ALIGNMENT OF THE KERB.
2. ALL CONCRETE FOR HAUNCHES UNDER PAVERS TO BE GRADE N25.
3. CLASS 2 FINISH FOR EXPOSED VERTICAL FACE GREATER THAN 200MM HIGH.

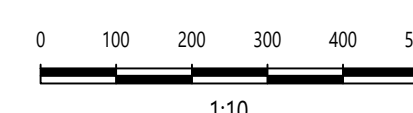
DRAFT

					SCALE ON ORIGINAL A3 SIZE DRAWING  0 100 200 300 400 500 1:10	DRAWN - CHECKED - DATE -	UNIT MANAGER APPROVAL ASSETS PLANNING AND DESIGN		CENTRAL COAST COUNCIL EDGING SERIES CONCRETE GARDEN EDGE	STANDARD DRAWING DRAWING NUMBER LSD302 REV A A3
REV	AMENDMENT	DATE	DRAWN	APRVD	ALL DIMENSIONS IN mm UNLESS OTHERWISE SHOWN					

NOTES

1. ALL CONCRETE FOR HAUNCHES UNDER PAVERS TO BE GRADE N25
2. REFER TO APPROVED TO LANDSCAPE AND ENGINEERING DRAWING FOR PAVER TYPE

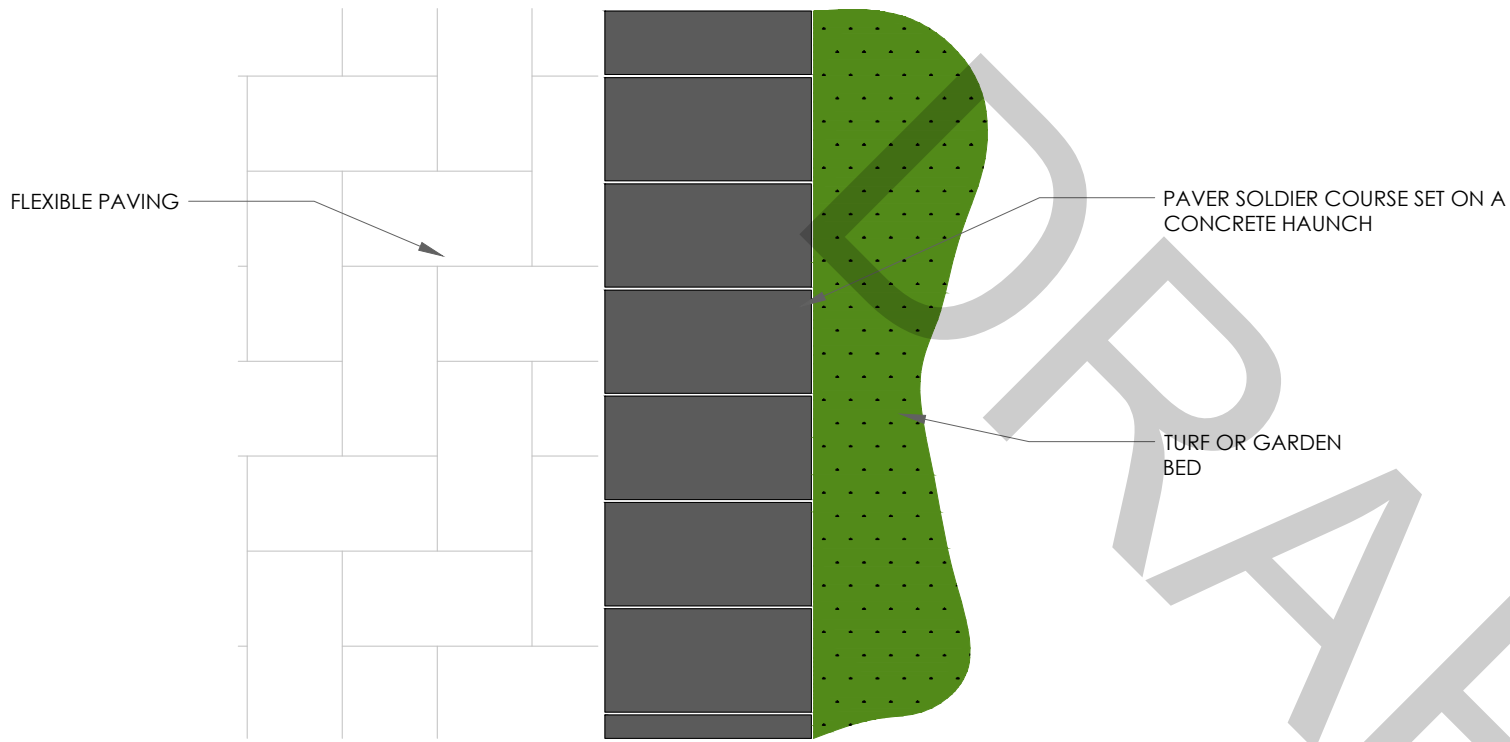

PLAN
PAVER EDGING TO GARDEN, SOFTFALL OR TURF
SCALE 1:10

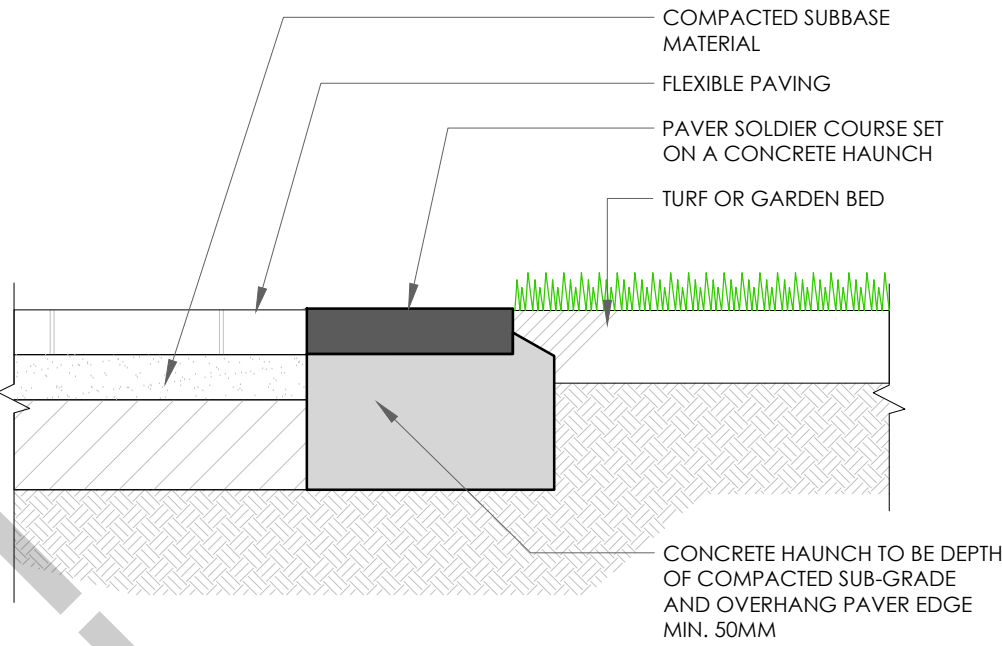

SECTION
SCALE 1:10

SCALE ON ORIGINAL A3 SIZE DRAWING

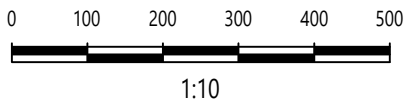

ALL DIMENSIONS IN mm UNLESS OTHERWISE SHOWN

DRAWN	-
CHECKED	-
DATE	-
UNIT MANAGER APPROVAL	
ASSETS PLANNING AND DESIGN	



CENTRAL COAST COUNCIL

EDGING SERIES
UNIT PAVER EDGE

STANDARD DRAWING

DRAWING NUMBER	REV
LSD303	#
--	A3

REV AMENDMENT

DATE DRAWN APRVD

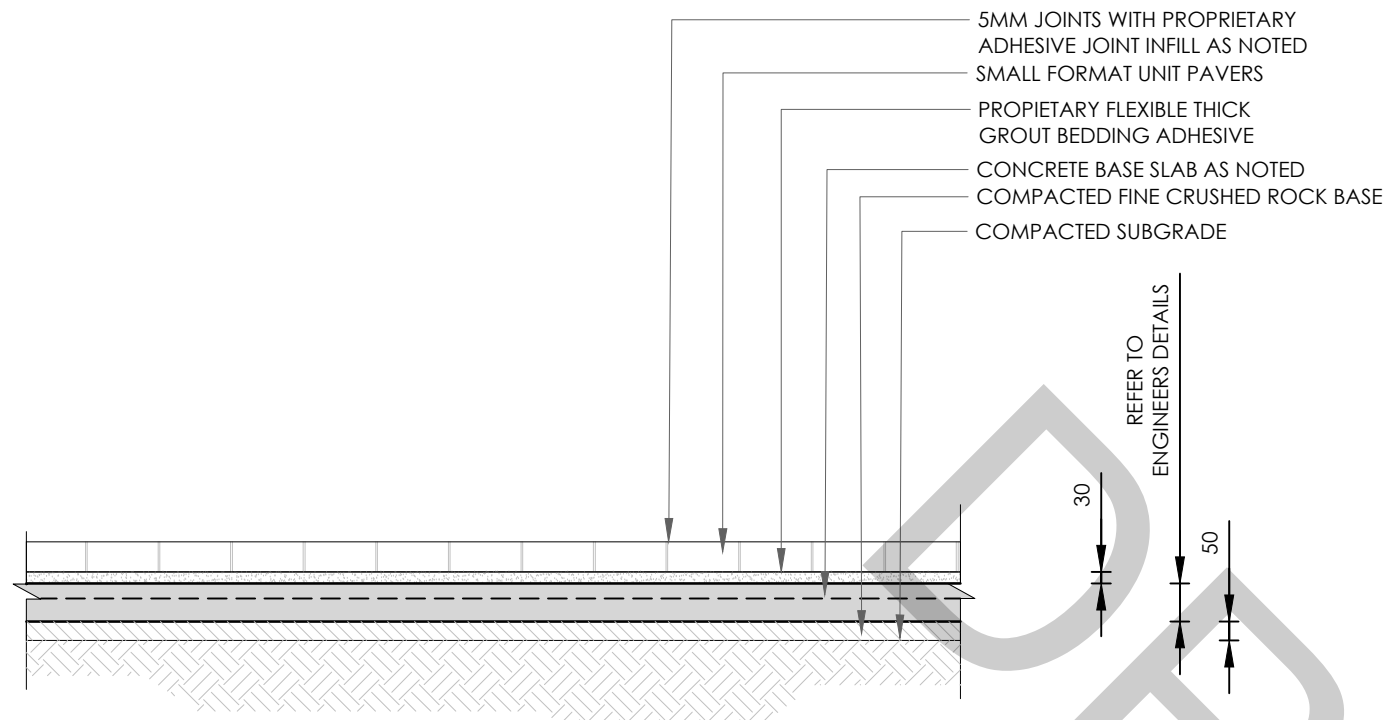

TYPICAL PAVER SECTION
SCALE 1:20

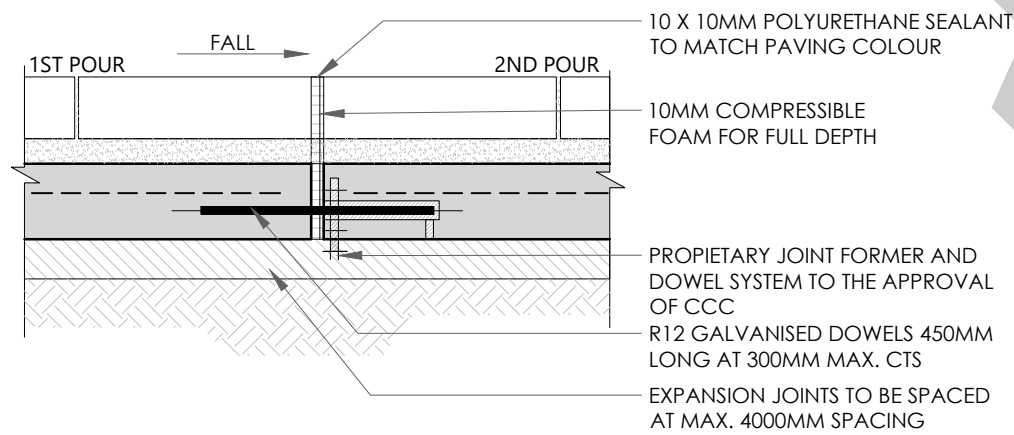

TYPICAL EXPANSION JOINTS
SCALE 1:10

NOTES

1. ALL WORKMANSHIP AND MATERIAL SHALL COMPLY WITH THE CURRENT AUSTRALIAN STANDARDS IN PARTICULAR AS3600 AND AS3727.
2. PAVEMENT IS TO BE FOUNDED ON FIRM NATURAL CUT GROUND OR COMPACTED FILL. ANY SOFT AREAS ARE TO BE REMOVED AND REPLACED WITH COMPACTED FILL TO MEET A MINIMUM OF 100Kpa ALLOWABLE BEARING PRESSURE.
3. ANY FILL MUST BE PLACED IN 150MM THICK MAXIMUM LAYERS AND COMPACTED TO A RELATIVE DRY DENSITY OF 98% TO AS1289.5.1.1.
4. THE BASE COURSE IS TO BE GRANULAR GRADED MATERIAL, SUCH AS FINE CRUSHED ROCK.
5. HARDSTANDS GENERALLY TO BE DESIGNED TO HAVE A 2.5% CROSS FALL. POORLY DRAINED SITE MAY REQUIRE SUB SURFACE DRAINAGE TO PROTECT PAVEMENT.
6. THE FINISHED LEVEL OF ANY PAVEMENT ABUTTING A WALL MUST BE BELOW THE DAMP PROOF COURSE AND MUST NOT OBSCURE ANY WEEP HOLES OR DRAINAGE OPENINGS.
7. DOWELS ARE TO BE ACCURATELY ALIGNED PARELLEL TO THE PAVEMENT SURFACE AND THE PAVEMENT CENTRE LINE. ALL DOWELS AND JOINT FORMERS ARE TO BE GALVANISED.
8. POLYURETHANE / SILICONE SEALANT TO MATCH PAVING COLOUR TO TOP 10MM JOINT.
9. CONCRETE THICKNESS, GRADE REINFORCEMENT AND COVER TO ENGINEERS DETAILS.
10. PREPARATION AND INSTALLATION OF BEDDING AND PAVERS IS TO BE IN STRICT ACCORDANCE WITH THE PAVER MANUFACTURES SPECIFICATIONS.
11. TOLERANCE 3MM MAX CHANGE IN HEIGHT EACH SIDE OF JOINT.
12. HARDSTAND PAVEMENT IS DESIGNED FOR LIGHT DUTY TRAFFIC LOADING (OPERATION OF VEHICLES NOT EXCEEDING 3 TONES). SEEK FUTHER ENGINEERING ADVICE FOR TRAFFIC LOADING EXCEEDING 3 TONNES.

REV	AMENDMENT	DATE	DRAWN	APRVD	SCALE ON ORIGINAL A3 SIZE DRAWING	DRAWN	-
					AS SHOWN	CHECKED	-
ALL DIMENSIONS IN mm UNLESS OTHERWISE SHOWN						DATE	-
						UNIT MANAGER APPROVAL	
						ASSETS PLANNING AND DESIGN	



CENTRAL COAST COUNCIL

PAVING SERIES
UNIT PAVER ON RIGID BASE

STANDARD DRAWING

DRAWING NUMBER	REV
LSD401	A
-	A3

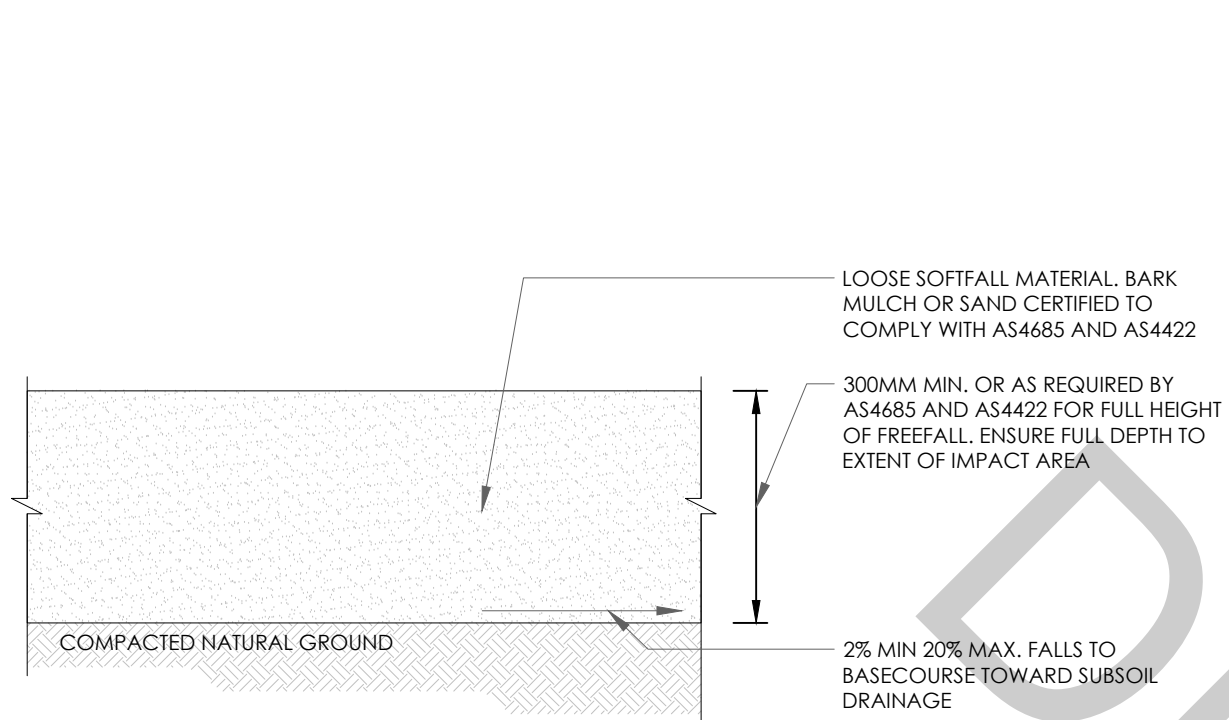

**BARK MULCH OR SAND
LOOSE SOFTFALL - TYPICAL PROFILE**
SCALE 1:10

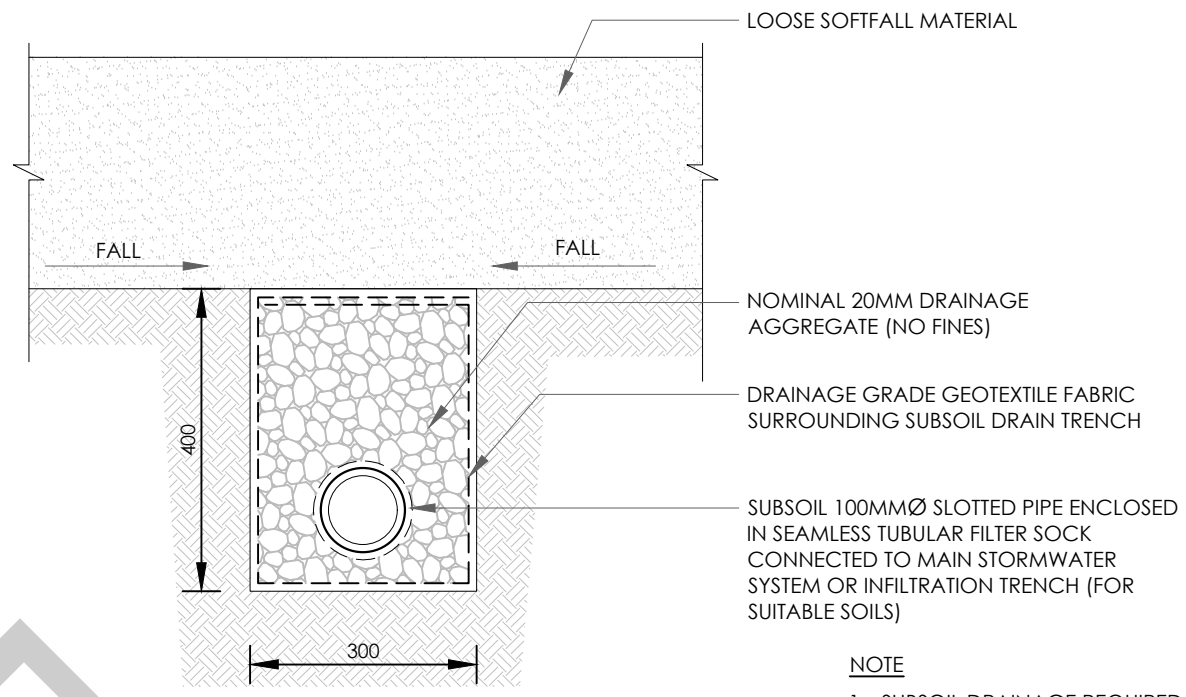

**BARK MULCH OR SAND
LOOSE SOFTFALL - SUBSOIL DRAINAGE**
SCALE 1:10

NOTE

1. SUBSOIL DRAINAGE REQUIRED IN POORLY DRAINED SITES AT MAXIMUM 5M CENTRES PARALLEL WITH CONTOURS. PROVIDE LAYOUT PLAN FOR CCC APPROVAL.
2. ALL SOFTFALL TO BE TESTED BY AN ACCREDITED SOFTFALL TESTER AT THE TIME OF INSTALLATION WITH A CERTIFICATE OF COMPLIANCE TO BE ISSUED TO CCC.
3. REFER TO APPROVED LANDSCAPE PLANS FOR SOFTFALL SCHEDULES.

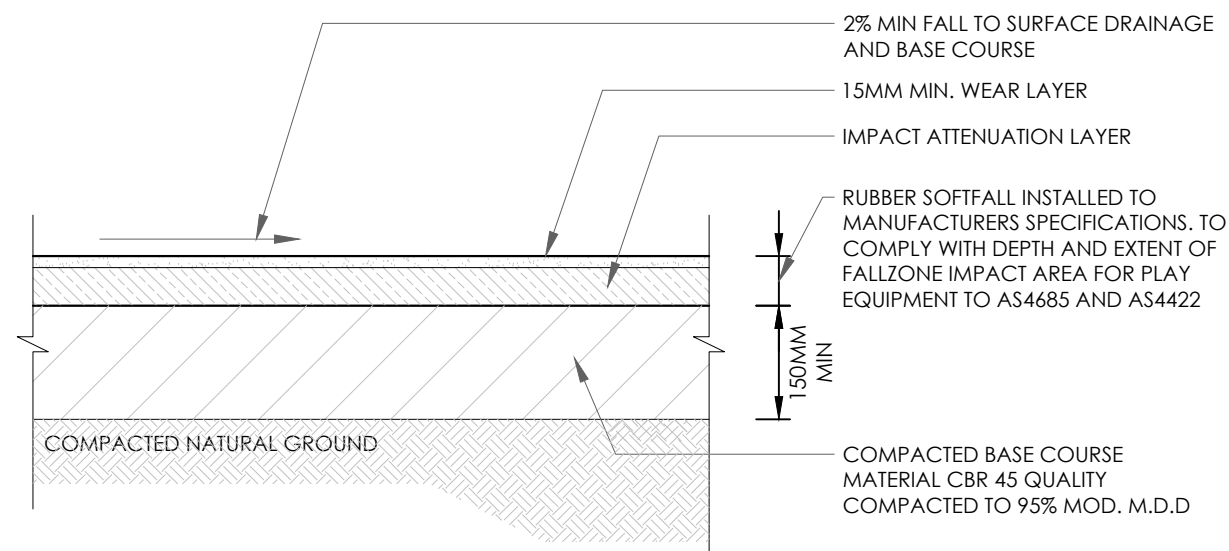

RUBBER SOFTFALL - TYPICAL PROFILE
SCALE 1:10

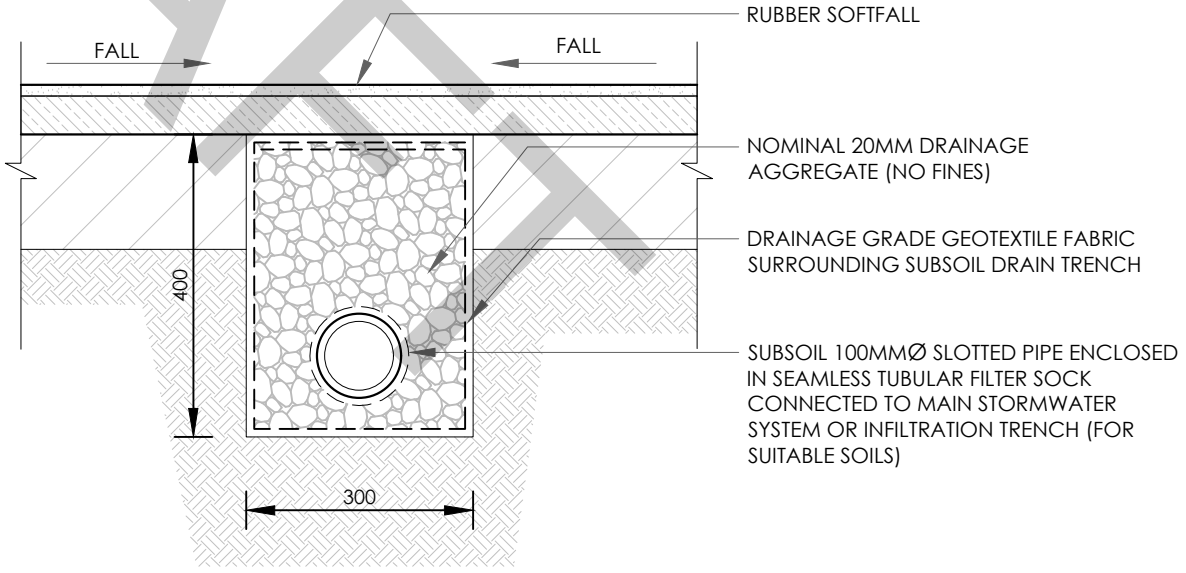

RUBBER SOFTFALL - SUBSOIL DRAINAGE
SCALE 1:10

SCALE ON ORIGINAL A3 SIZE DRAWING

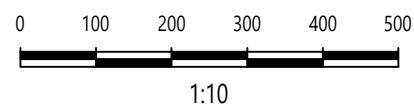

DRAWN -
CHECKED -
DATE -

UNIT MANAGER APPROVAL



CENTRAL COAST COUNCIL

**PLAYGROUND SOFTFALL SERIES
PLAYGROUND SOFTFALL - BARK,
MULCH & RUBBER**

STANDARD DRAWING

DRAWING NUMBER
LSD501

REV
A

- A3

REV	AMENDMENT	DATE	DRAWN	APRVD	ALL DIMENSIONS IN mm UNLESS OTHERWISE SHOWN	ASSETS PLANNING AND DESIGN

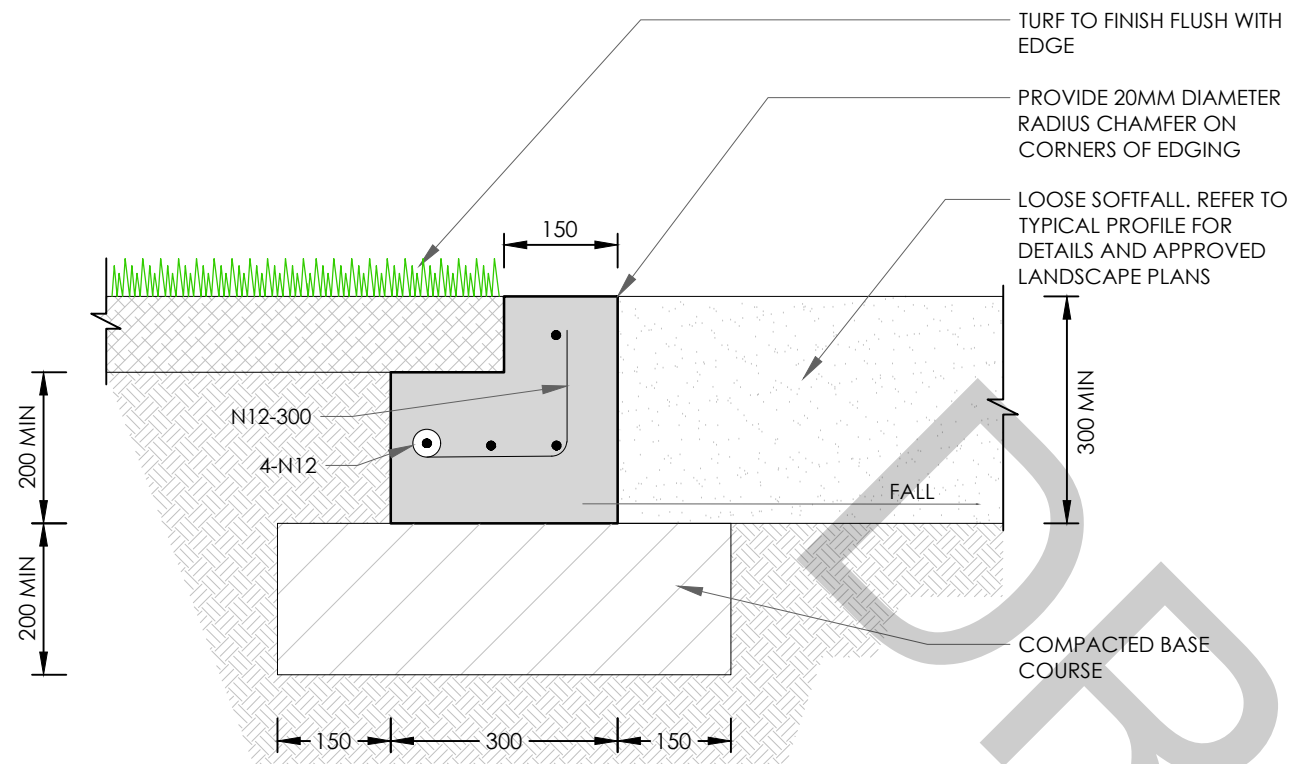

TURF EDGING
LOOSE SOFTFALL - LEVEL EDGING (TYPE 1)
 SCALE 1:10

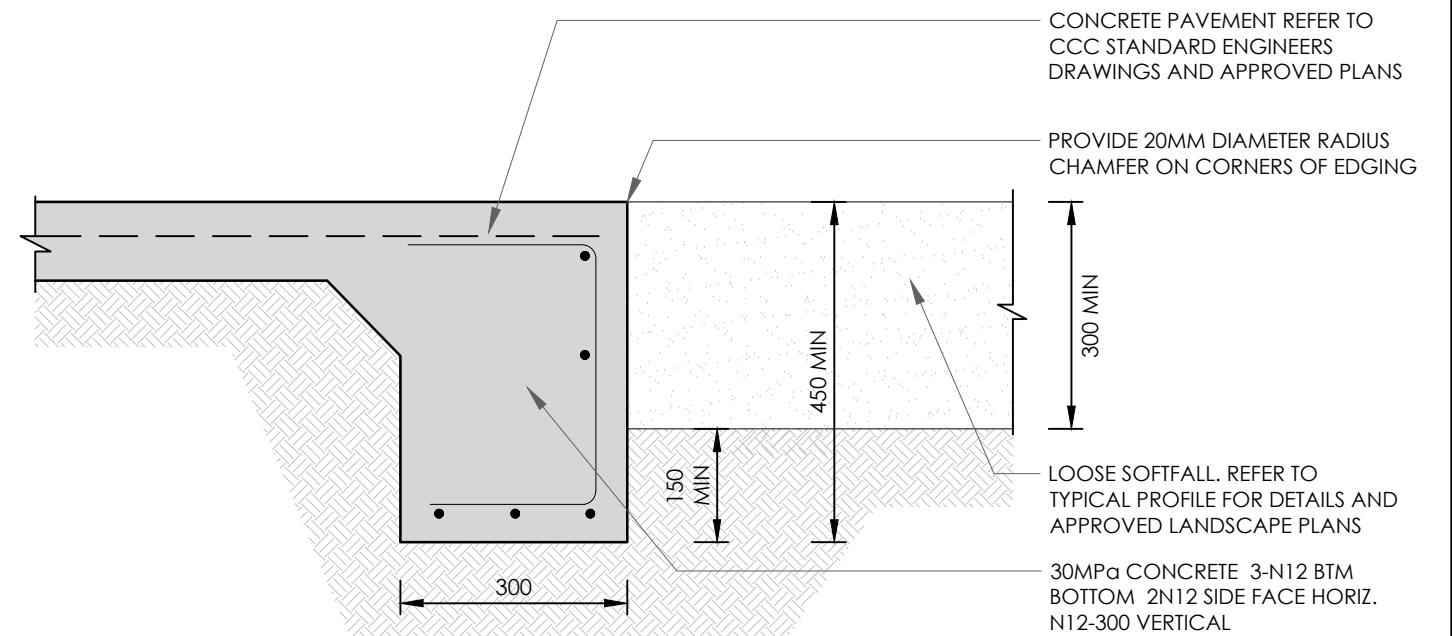

CONCRETE PAVEMENT EDGING
LOOSE SOFTFALL - LEVEL EDGING (TYPE 2)
 SCALE 1:10

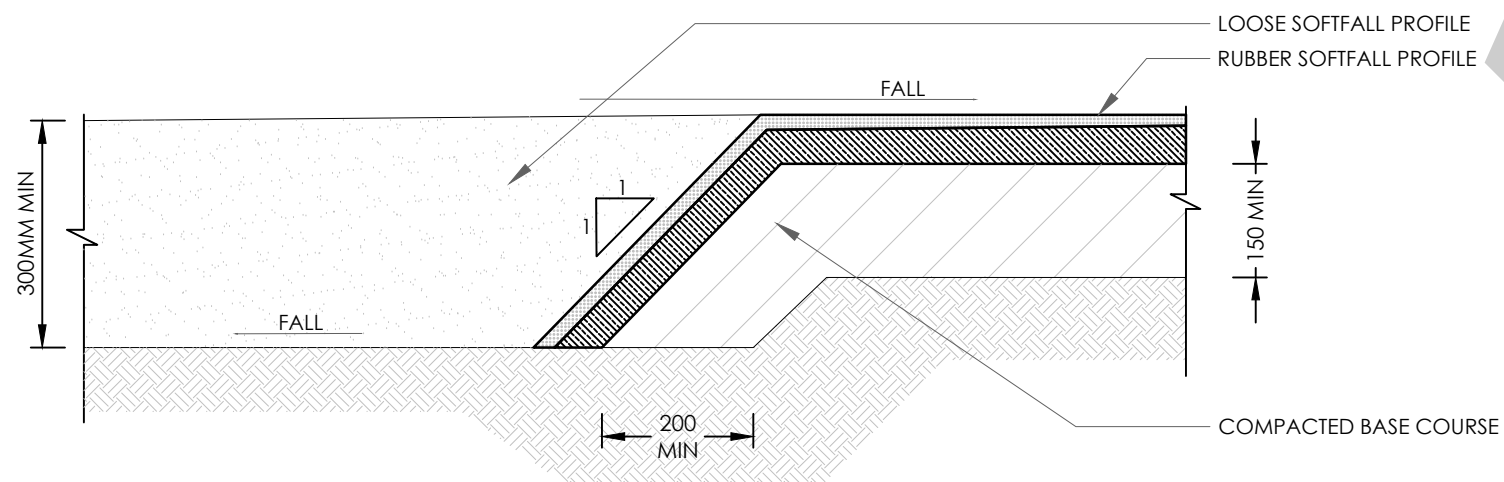

JUNCTION OF LOOSE SOFTFALL & RUBBER SOFTFALL / WEAR PAD
 SCALE 1:10

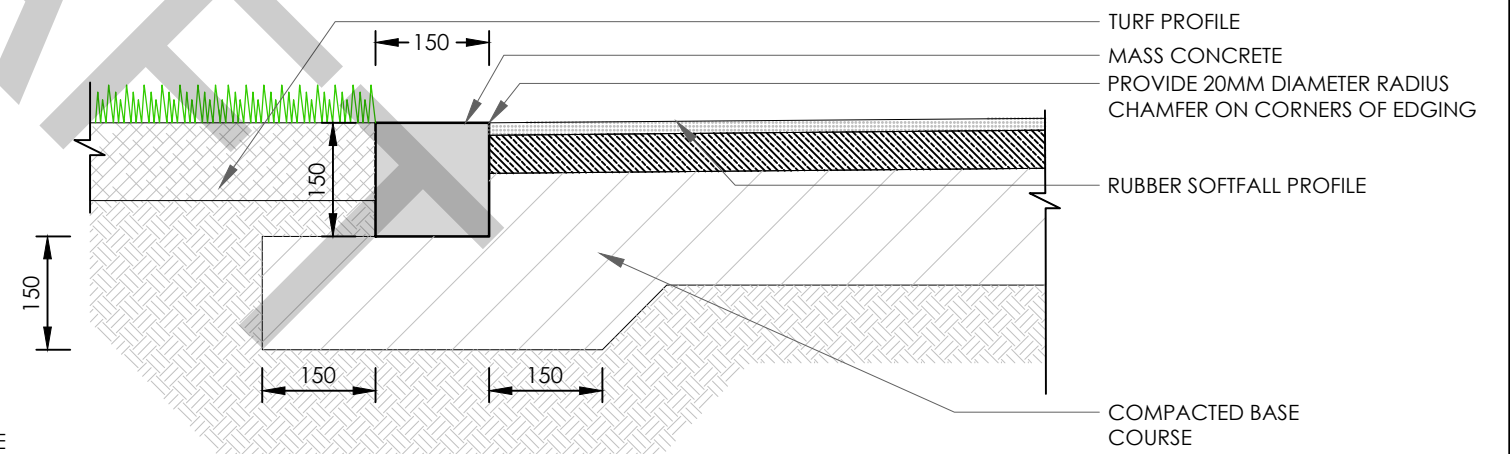

TURF OR CONCRETE PAVEMENT EDGING
RUBBER SOFTFALL - LEVEL EDGING
 SCALE 1:10

SCALE ON ORIGINAL A3 SIZE DRAWING

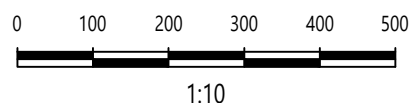

DRAWN -
 CHECKED -
 DATE -

UNIT MANAGER APPROVAL



CENTRAL COAST COUNCIL

PLAYGROUND SOFTFALL SERIES
 SOFTFALL EDGING

STANDARD DRAWING

DRAWING NUMBER	REV
LSD502	A
--	A3

REV	AMENDMENT	DATE	DRAWN	APRVD	ALL DIMENSIONS IN mm UNLESS OTHERWISE SHOWN	ASSETS PLANNING AND DESIGN
-----	-----------	------	-------	-------	---	----------------------------

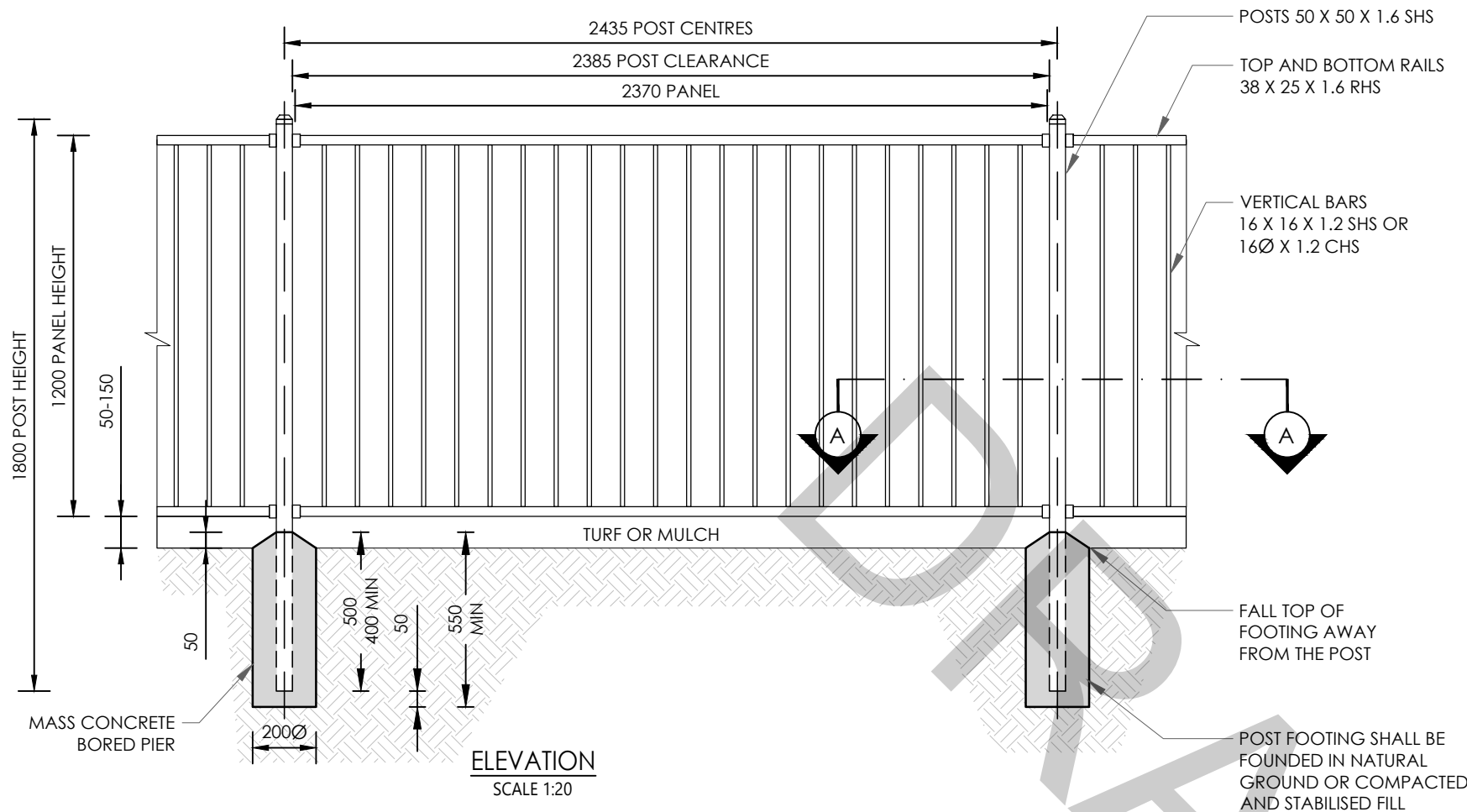

ELEVATION
SCALE 1:20

NOTE

1. GATE, END AND INTERMEDIATE POSTS TO BE 50 X 50 X 1.6MM SHS GALVANISED TO AS1163.
2. PANELS TO BE FIXED TO POSTS USING MANUFACTURER SUPPLIED SOCKET CONNECTORS OR 35 X 35 X 2.0MM GALVANISED STEEL 'L' BRACKETS. BOTH CONNECTIONS TO BE ATTACHED WITH GALVANISED 12 - 14 X 20MM HEXAGON HEAD SELF DRILLING TEX SCREWS.
3. VERTICAL BARS TO PASS THROUGH TOP AND BOTTOM RAILS AND SECURED TO RAIL WITH 6MM SPOT WELD. SHS TO PASS THROUGH AT 45° ANGLE.
4. ALL WELDS TO BE SILICONE BRONZE WELDS (NOT MILD STEEL WHEEL WELDS) TO SUIT THE PROTECTIVE FINISH SPECIFIED.
5. ALL STEEL ELEMENTS ARE TO BE HOT DIP GALVANISED TO PROVIDE A MINIMUM ZINC RATING OF 2275. FERROUS OPEN SECTIONS TO AS4791, FERROUS HOLLOW SECTIONS TO AS4792.
6. ALL STEEL ELEMENTS TO BE POWDER COATED (UV STABILIZED) TO AS4506. COLOUR TO BE CONFIRMED WITH CCC.
7. ALL CONCRETE TO BE GRADE N20.
8. POSTS ARE TO BE VERTICAL.
9. RAKE PANELS FOR SLOPE UP TO 1 IN 5. DESIGN TO MINIMISE THE NUMBER OF STEPS IN ANY RUN.
10. ENSURE 1200MM MIN CLEAR SPAN FROM TOP OF FENCE TO ANY CLIMBABLE OBJECT OUTSIDE THE FENCE AREA THAT MAY PROVIDE A FOOTHOLD IE. ROCKS, STEPS, BANKS OR TREES WITH LOW BRANCHES.
11. ENSURE 100MM MAX GAP BETWEEN END POST AND ABUTTING BARRIER.
12. FENCE TO BE INSTALLED GREATER THAN 1000MM AWAY FROM THE EDGE OF A SHARED PATH.

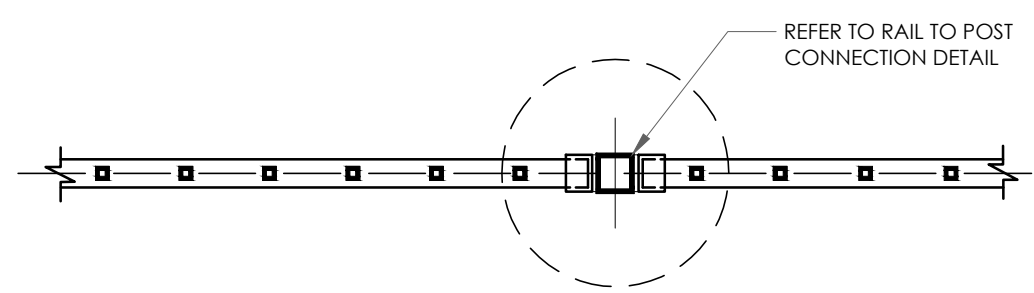

PLAN VIEW A - A
SCALE 1:20

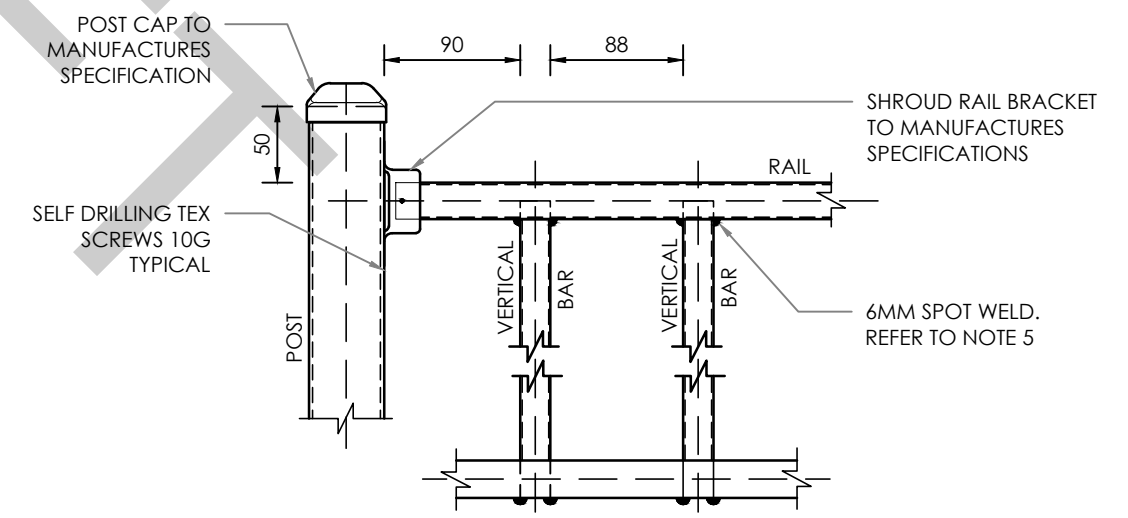

TYPICAL CONNECTION DETAIL
SCALE 1:5

REV	AMENDMENT	DATE	DRAWN	APRVD	SCALE ON ORIGINAL A3 SIZE DRAWING	DRAWN	-		CENTRAL COAST COUNCIL	STANDARD DRAWING	
					AS SHOWN	CHECKED	-			DRAWING NUMBER	REV
						DATE	-		FENCING SERIES	LSD601	A
						UNIT MANAGER APPROVAL			CHILD SAFETY FENCE	--	A3
					ALL DIMENSIONS IN mm UNLESS OTHERWISE SHOWN	ASSETS PLANNING AND DESIGN					

CENTRAL COAST COUNCIL SOILS SPECIFICATION
Summary of Expected Actions and Responsibilities

Section	Action	Responsibility
1	Identification of Soil Resources (Survey of soil type, depth of topsoil and subsoil, chemical and physical properties)	1. Head Contractor or Soil Scientist engaged by Head Contractor 2. Records to be kept by Head Contractor
2	Assessment of Soil Suitability	1. Head Contractor to develop a plan or engage a Soil Scientist to do so 2. Records and evidence to be kept by Head Contractor 3. Soil Scientist to provide amelioration advice
3	Identification of Landscape Types	• Developer, Consultant and Council to define landscape types and 'value'
4	Soil Specifications	• Developer, Consultant and Council to define which landscape types are applicable • Head contractor to understand testing requirements
5	Stripping and Stockpiling Plan	4. Head Contractor or Contractor conducting bulk earthworks, advice from soil scientist where needed. • Records to be kept by both Contractors.
6	Topsoil Amelioration Process	• Landscape Contractor to execute recommendations on site • Landscape Contractor to keep records of inputs and process
7	Certification and Validation	• Landscape Contractor to conduct sampling or engage a Soil Scientist to do so • Soil Scientist to provide interpretation / sign off / additional amendments • Landscape Contractor to keep record of certification or conduct corrective actions (and record of input)
8	Subgrade Preparation	• Head Contractor or Landscape Contractor
9	Topsoil Spread	• Landscape Contractor to execute 1. Landscape Contractor to keep records of quantities.

1.0 Identification of Site Soil Resources

- When control of the site is taken over by the Head Contractor, any areas identified to have potential for site soil recovery for re-use must be assessed for depth and composition. Soil profiles on site must be assessed to determine the depth of A Horizons (Topsoil), B Horizons (Subsoil) and C Horizons (Bedrock) if present.
- Soil Horizon categories are typically identified by the following:
 - Horizon is a valuable resource and can be (in most cases) easily re-used on-site with some amelioration. Typically, the A Horizon is an organic, friable loam material with vegetation growing within.
 - Horizon can also be re-used as subsoil in landscaping applications; however, must be stripped and stockpiled separately to allow for specific treatment. B Horizon tends to have a higher clay content, nil or no organic matter and can be brightly colored.
 - Horizon is rarely economically viable for re-use in landscaping and is typically used for fill. However, where A or B Horizon cannot be utilised on site, C Horizon may be amended into a useable topsoil. C Horizons, if encountered, tend to be rocky, (shale / sandstone) and may be difficult to penetrate.
- The re-use of site soils is to be undertaken unless they are found to be unsuitable to avoid the disposal of soil as general solid waste and the need for importation of new soil.
- For small sites (<1 ha), a suitably qualified representative from the Head Contractor may carry out a simple assessment of soil depths of A/B and C Horizons, prior to establishing the stripping depth and/or providing estimates of recovered soil volume. Where the Head Contractor is not able to define these characteristics, a Soil Scientist is to be engaged. A minimum of 3 investigatory boreholes is to be conducted across the site in areas of variable slope and terrain to gain an accurate assessment.
- For sites with a development footprint of >1 ha, a suitability qualified soil scientist is to be engaged to characterise soils across the area and provide a stripping guide for the site. Soils can differ in quality, composition, and limitations across larger areas, and may require separation during the stockpile process to allow for different amelioration practices to be applied. Separation of stockpiles of poorer quality are to be delineated from those of higher quality.
- The Head Contractor is required to maintain a record of measured topsoil / subsoil depth from each borehole constructed in the investigation. Once A and B horizons have been identified, estimates may be made for the recoverable soil volume and estimated stripping depth.
- The Head Contractor is required to be aware of what the B Horizon characteristics are and that B Horizons are to be stripped and stockpiled separately to topsoil material.
- Protect the site from unnecessary damage to soils during early site works. During initial site investigations, minimise disturbance to the site as far as possible by limiting driving heavy machinery, uncontrolled earth movements and installations. Limit site installations to site sheds and access roads and prevent free access movement of all vehicles. Fence to prevent illegal waste dumping.

2.0 Assessment of Soil Suitability

Soil Sampling

- All topsoil that is to be re-used or imported to site must be surveyed, sampled and

REV	AMENDMENT	DATE	DRAWN	APRVD	SCALE ON ORIGINAL A3 SIZE DRAWING	DRAWN	CHECKED	DATE	UNIT MANAGER APPROVAL	ASSETS PLANNING AND DESIGN
						-	-	-		

- analysed to determine suitability. Soil samples are to be submitted to a NATA accredited soil laboratory. Results produced by the laboratory must be reviewed and interpreted by a suitably qualified Soil Scientist. The Soil Scientist is required to provide a report outlining any non-compliances with the relevant soil specifications and provide amelioration advice to achieve a fit for purpose soil for landscaping use.
- It is the responsibility of the Head Contractor to engage the services of the Soil Scientist during the project and retain records. The Landscape Contractor is required to follow the amelioration advice provided by the soil scientist, and retain records of treatment inputs.
 - Soil is to be sampled in-situ (prior to stripping) or, if not already tested, then within the stockpile. In the instance soils are to be imported to site, the Head Contractor must contact soil suppliers for representative samples of the product for analysis.
 - Soils are to be tested at a minimum frequency of one composite soil sample per 750m³ of material. A composite sample is defined as a large (3L) bag of soil that is made up of 5-10 smaller subsamples, mixed to make a sample for testing (SFT). The calculated number of samples required for testing is to be rounded up, rather than down.

Testing Suites

- Samples for testing must be analysed for the most relevant suite of analysis provided in Section 4. In the instance that the landscape situation and associated value is not established, clear or otherwise unknown, it is the responsibility of the Head Contractor and Developer to confirm with Council what suite is best fitting.
- The Head Contractor is to conduct soil sampling (or engage a subcontractor to do so) based on the identified landscape situation and associated value. Samples are to be submitted to a NATA accredited laboratory for analysis.

Subgrade / Subsoil Characterisation

- Once topsoil is stripped and stockpiled, the shallow depths of exposed subsoil is to be determined if the subsoil is free of chemical and physical limitations and will be supportive of landscape establishment. It is the responsibility of the Head Contractor to conduct sampling and engage a Soil Scientist to conduct the soil sampling.
- Recovered B Horizon may be used for subsoil (below 300mm) backfill for tree pits, however must be tested to the requirements of the specifications in Specification 4 - Tree Pits, Low Value, Below 300mm (B Horizon), ameliorated and re-installed as per the detail drawings.
- Where topsoil is to be spread on top of exposed B or C Horizon or jumbled mixes of these, it is required that such subgrade be characterised prior to installation. Mixed subgrade horizons are to be sampled at 1 composite sample per 1/4 ha. Subgrade and subsoil material must be tested to the requirements presented in Specification 11 - Subgrade Specification, and the process outlined in Section 6 is to be carried out.
- The Head Contractor is to engage a Soil Scientist for amelioration advice using the results from the laboratory analysis.

Interpretation of Results and Recommended Amelioration

- Results are to be obtained from the laboratory for each of the required analysis outlined in Section 4 and to be presented to a suitably qualified Soil Scientist for review. The Soil Scientist must identify the non-compliances and limitations of the soil and provide an amelioration plan that may be executed by the Head or Landscape Contractor to achieve a fit for purpose soil. Where available, the contractor is to supply a species list and details to the Soil Scientist so that amelioration advice can be tailored specifically to the project and selected species.
- It is the responsibility of the Landscape Contractor to read and fully understand the requirements of the amelioration advice and conduct the amelioration as per the report. Where products prescribed by the Soil Scientist cannot be sourced or are economically unfeasible, the contractor must seek the advice of the Soil Scientist to determine a suitable substitute.

3.0 Identification of Landscape Types

- The Developer is to define and confirm with Council what landscapes are to be established across the site prior to the assessment of suitability. It is the responsibility of the Developer to identify how the value of landscapes are to be allocated to each landscaping area.
- Definition of landscape units to determine Specification Type and testing requirements is outlined in the following table.

Landscape Unit	Description
High Value	Best described as landscape areas of high value. Situations include landscapes that are in constant view of the public, with the expectation of fast growth and long-lasting visual impact. Examples would be landscapes around shopping centers, parks, high-rises, display beds, road verges, entrances and other frequently visited or viewed areas. Soil types used within high value applications are expected to have high nutrient levels for sustained optimum growth.
Low Value	Best described as landscapes of lesser value. Situations include landscapes that are less frequented and expected to support vegetation, but instant impact is not critical and maintenance is minimal. Examples would be mass planting areas within residential developments, revegetation and buffer spaces, riparian areas and other less frequented areas. Soil types within low value applications are expected to have reasonable (but not high) nutrient levels that are supportive of long-term growth.

Landscape Unit	Description
General Mass Plantings	Landscapes containing plantings of generalist species (native and/or exotics) which are imported as smaller tube stocks. Establishment is typically slow. Topsoil depth ranges from 200 - 300mm and may be overlying subsoil or subgrade material. Planting pallets are typically grasses, woody and herbaceous perennials with reasonably low nutrient requirements. Planting methods are typically direct seeding, tubes and plant stock up to 45L.
Advanced Tree Plantings	Landscapes supporting larger specimens (45L or more). Pits are dug into the soil (typically 600mm in depth), backfilled with A and B Horizons and drainage. Advanced tree plantings are defined as excavated holes with ameliorated topsoil and subsoil reinstalled in the correct order. Tree vaults are a higher level of engineered systems such as Stratavaults, Cell Systems, Structural soils or otherwise. Soil types used within high value applications are expected to have high nutrient levels for sustained optimum growth.
High Traffic	Areas of significant foot traffic and regular use. Areas typically include public spaces, near entrances, parks and other areas where people are expected to walk on grassed areas. Soil type is expected to be a well-drained sand which is resistant to compaction with some organic matter. This definition does not include applications for sportsfields.
Low Traffic	Areas of lesser foot traffic and only occasional recreational passive use. Areas are typically grassed mounds, street verges, residential lawns, nature strips and other areas where grasses are being established and people are rarely expected to walk on. Soil type is expected to be a well-drained sand with organic matter.
Under Pavement	Horticultural landscapes installed under footpaths, structures or buildings. It is expected that the soil resource for growing plants is partially or fully covered by these structures.
Structural Soils / Soils with Aggregates	Soil systems consisting of large aggregates and 'filler soil', allowing for the support of structures / footpaths and horticultural landscapes.
Cell Systems	Soil systems, usually constructed from high strength plastic that are filled with soil allowing for the support of structures / footpaths and horticultural landscapes.
Raingarden	Garden beds comprising of various sand and gravel materials designed specifically for the removal of nutrient from stormwater. Stormwater is typically diverted into these systems for filtration prior to release into stormwater lines. The secondary purpose of raingardens is to support the growth of riparian species, which facilitate further nutrient removal.

4.0 Soil Specification

- References in this specification to Appendix A and associated Tables are to be sourced from *Soils for Landscape Development* Leake and Haeger 2014. AS4419:2018 *Soils for Landscaping and Garden Use* is the relevant Australian Standard to be referenced in this specification.
- The following Soil Specification Types include:
 - Specification 1 - General Mass Plantings, Low Value:** Requires testing to AS4419:2018 Table 1 - Landscape Soils (On Grade) and additional testing for texture and structure. The soil must fit into the criteria of at least one category within AS4419:2018 Table 1, be friable in nature and have an estimated infiltration >20 mm.
 - Specification 2 - General Mass Plantings, High Value:** Requires testing to specification D2 within *Soils for Landscape Development* Leake and Haeger 2014. The required analysis and target ranges have been provided in Appendix A - Table 1.
 - Specification 3 - Tree Pits, Low Value, Top 300mm (A Horizon):** Requires testing to AS4419:2018 Table 1 - Landscape soils (On Grade) and additional testing for texture and structure. The soil must fit into the criteria for the 'Medium Organic Matter' category within AS4419:2018 Table 1, be friable in nature and have an estimated infiltration >20 mm.
 - Specification 4 - Tree Pits, Low Value, Below 300mm (B Horizon):** Requires testing to AS4419:2018 Table 1 - Landscape soils (On Grade) and additional testing for texture and structure. The soil must fit into the criteria for the 'Low Organic Matter' category within AS4419:2018 Table 1, with organic matter ≤ 3%, be friable in nature and have an estimated infiltration >20mm.
 - Specification 5 - Tree Pits, High Value, Top 300mm (A Horizon):** Requires testing to specification D2 within *Soils for Landscape Development* Leake and Haeger 2014. The required analysis and target ranges have been provided in Appendix A - Table 2.
 - Specification 6 - Tree Pits, High Value, Below 300mm (B Horizon):** Requires testing to AS4419:2018 Table 1 - Landscape soils (On Grade) and additional testing for texture and structure. The soil must fit into the criteria for the 'Low Organic Matter' category within AS4419:2018 Table 1 with organic matter ≤ 3%, be friable in nature and have an estimated infiltration >20 mm.
 - Specification 7 - Tree Pits Under Pavement - Cell Systems:** To be applied only in the instance that there is no previous, system specific soil specification from the manufacturer. Specification 7 requires testing to Specification D2 within *Soils for Landscape Development* Leake and Haeger 2014. The required analysis and target ranges have been provided in Appendix A - Table 3.
 - Specification 8 - Tree Pits Under Pavement - Structural Soils with Aggregates:** To be applied only in the instance that there is no previous, system specific soil specification from the manufacturer. Specification 8 requires testing to

specification F1 within *Soils for Landscape Development* Leake and Haeger 2014. The required analysis and target ranges have been provided in Appendix A - Table 4.

- Specification 9 - Turf, Low Traffic:** Requires testing to specification C1 within *Soils for Landscape Development* Leake and Haeger 2014. The required analysis and target ranges have been provided in tables Appendix A - Table 5.
- Specification 10 - Turf, High Traffic:** Requires testing to specification C2 within *Soils for Landscape Development* Leake and Haeger 2014. The required analysis and target ranges have been provided in Appendix A - Table 6. This specification is not intended for sportsfield use.
- Specification 11 - Subgrade Specification:** Requires testing to a simplified version of specification B3 *Soils for Landscape Development* Leake and Haeger 2014. The required analysis and target ranges have been provided in Appendix A - Table 7.

5.0 Stripping and Stockpiling

- Stripping and stockpiling of topsoil is to occur immediately before bulk earthworks and be done in such a manner that minimises erosion and sediment loss from site. Ensure that rubbish and foreign matter is removed in the stripped soil. It is the responsibility of the Head to ensure stripping and stockpiling is conducted correctly.
- Stockpiles must be in a convenient place away from any risk of running water and subject to suitable erosion control measures. They must be protected from contamination during the construction process and records kept of their location and type of soil contained.
- The following table provides a summary of the stripping and stockpiling process required on site.

Landscape Unit	Description
Preparation	2. Clear all debris including demolition waste, timber, rubbish wire fences, rock, graveled driveways, etc. 3. Clear trees and shrub growth and slash if necessary. 4. Clear trees, pasture and weed growth. If heavy or otherwise a problem, spray with a broad-spectrum herbicide at manufacturer's rates and allow 1-2 weeks to obtain kill before stripping. Obtain Specific advice on weed control.
Stripping	5. Avoid the inclusion of subsoil in topsoil stripping, adjust depth accordingly. Strip to the recommended depths and generally stop stripping if the more brightly coloured or more clayey subsoil starts showing. 6. Strip topsoil to depths as defined from the process in Section 1 including all surface leaf litter, plants and grasses.
Locate stockpiles in a convenient location	• Locate stockpiles 5m or more from concentrated water flows (including drainage lines, roadways). • Locations should have less than 10% slope. • Locate greater than 8m from any retained trees. • Protect upslope using diversion drains. • Protect downslope sediment loss using sediment control structures (silt fencing or other approved method).
Management	• Stockpiles must never be trampled. Fence stockpiles to exclude all vehicles. • Stockpiles must be no higher than 2m but may be flat topped. • Where space is limited within the site footprint, stockpiles may be higher than 2m (to a maximum of 4 m), however batters of the stockpile must remain at a slope of 2:1. Stockpiles may be flat topped if required. • Label stockpiles with origin, soil type and date. • Protect stockpiles from waste and rubbish dumping and encroachment of works. • If stockpiles are to be in place longer than 3 months, sow with a seasonally appropriate annual cover crop.

6.0 Topsoil Amelioration

- It is the responsibility of the Landscape Contractor to conduct amelioration on site (or ensure soils are ameliorated prior to import to site). The method for ameliorating soils on-site is at the discretion of the contractor and it is expected to be carried out in the most economical, but effective manner possible. As a guide, two common methodologies for on-site amelioration for consideration include:
 - In-Situ Amelioration:** For soils that are to be ameliorated in-situ (i.e not stripped and stockpiled, left in place). The following process can be carried out:
 - Determine topsoil depth and amelioration depth (typically 100mm).
 - Prepare area by spraying cover crop and weeds (if required).
 - If possible, rip topsoil and subsoil to a maximum depth possible with available machinery (it is important to note ripping is not to be confused with cultivating - subsoil and topsoil materials are not to be mixed together).
 - Surface apply amendments such as sand, compost, gypsum or lime (not fertilisers) at the prescribed g/m².
 - Cultivate (using a disc plough or otherwise) into the top 100mm to incorporate amendments.
 - Surface apply fertilisers at the prescribed g/m².



CENTRAL COAST COUNCIL
SPECIFICATION SERIES
SOIL SPECIFICATION - SHEET 1

STANDARD DRAWING	
DRAWING NUMBER	REV
LSD801	A
-	A3

6.1.2 Stockpile Amelioration: For soils that have been stored in stockpile (i.e stripped and stockpiled onsite during earthworks) the following process are be carried out:

- Prepare stockpile by spraying cover crop and weeds (if required).
- Break down the stockpile in known volumes with an excavator or front-end loader, creating smaller piles of known volume.
- Screen material with a screening bucket.
- Apply amendments such as sand, compost, gypsum or lime (not fertilisers) at the prescribed g/m³.
- Thoroughly mix amendments into the soil.
- Spread topsoil in the specified location, at the required depth.
- Surface apply fertilisers at the prescribed g/m².

7.0 Topsoil Certification and Validation

- 1.1. After topsoil has been ameliorated (regardless of in-situ or stockpile), the soil material must be validated to ensure the amelioration has been carried out in an effective manner. Ameliorated soil is to be sampled and analysed for the nominated Soil Specification Type. It is the responsibility of the Landscape Contractor to engage a Soil Scientist to collect samples and provide interpretations.
- 1.2. The same process outlined in Section 2 are to be carried out, however soil may be sampled at 1 composite sample per 1,000m³.
- 1.3. An appropriately qualified Soil Scientist is required to review the laboratory results and provide commentary on whether the soil may be considered 'fit for purpose' or any additional amelioration is required.

8.0 Subgrade Preparation

- 8.1. Exposed subgrade or recovered subsoil from stockpiles are to be treated in-situ or as it is exploited from the stockpile. Records and evidence of amelioration of subgrade and subsoil treatment must be provided.
- 8.2. The method for cut, fill and amendment of subgrade / subsoil on-site is at the discretion of the Head Contractor and it is expected to be carried out in the most economical, but effective manner possible.
- 8.3. The required steps for subgrade / subsoil preparation and amelioration for areas to have topsoil spread are as follows (Note this process does not apply to subsoil backfill for tree vaults or larger stock):
 1. Fair and trim to relative level to accommodate the required overall soil depths.
 2. Remove rocks >50 mm diameter.
 3. Remove rubbish such as construction generated waste, plastics, metals and glass.
 4. Deep rip to a maximum depth allowable by available machinery.
 5. Apply ameliorants as per the Soil Scientist's reports.
 6. Chisel, disc plough or use an excavator with a tyne attachment to loosen the subgrade and mix the ameliorants to 200 mm depth to incorporate.
- 8.1. Where stockpiled recovered subsoil is applied to cut subgrade, the subgrade shall not be compacted to more than about 70-80% proctor compaction rate. The recovered subsoil from stockpile can be treated in-situ after spreading in the manner described above. It is important to avoid excessive compaction of subsoils and to relieve compaction if it occurs prior to placing topsoil.

9.0 Topsoil Spread and Preparation for Planting

- 9.1. Validated ameliorated topsoil is to be spread by the Landscape Contractor where required at the nominated depth. Processed topsoil compliant to the specifications is prone to compaction and it is imperative that the following considerations are made when spreading topsoil and preparing for planting:
 1. Under no circumstances, is topsoil to be compacted by any means beyond light 'firming'.
 2. If soils are required to be stabilised due to slope, water runoff or otherwise, specified erosion control measures are to be installed immediately after topsoil spread.
 3. All vehicle traffic, inclusive of light vehicles, machinery or otherwise is to be excluded from areas with topsoil that has been spread.
 4. In the event that compaction is unavoidable due to site operations, it is the responsibility of the Landscape Contractor to relive soil compaction by tyning or cultivation prior to planting.
 5. Plants and/or cover crops are to be installed as soon as practicably possible after topsoil spread.

Appendix A - Soil Properties Tables

The following tables provides the soil properties requirements for each Soil Specification type identified in 4. Soil Specification.

Table 1: Specification 2 – General Mass Plantings, High Value			
Physical Properties			
Property	Units	Target Range	
Texture, preferred range ¹	n/a	Sandy loam to clay loam	
Organic matter ²	% dwb	3-6	
Permeability (@ 16 drops by McIntyre Jakobsen) ³	mm/h	> 30	
Wettability ⁴	mm/h	> 5	
Dispersibility in water ⁷	Class	> 4	Emerson Aggregate Class
Large particles (naturally occurring) ⁴			
2-20 mm	% w/w	< 20	
> 20 mm	% w/w	< 10	
Visible contaminants > 2 mm (glass, plastic and metal) ⁵	%w/w	< 0.5	
Chemical Properties			
Property	Units	Target Range	
pH in water (1:5) standard range ⁶	pH units	5.4-6.8	
pH in CaCl2 (1:5) standard range ⁶	pH units	5.2-6.5	
Electrical conductivity (1:5) ⁶	dS/m	< 0.65	
Phosphorus – P-sensitive plants. Acid soils method ⁶	mg/kg	< 30	
Phosphorus – P-Tolerant plants. Acid soils method ⁶	mg/kg	30-60	
Exchangeable sodium (Na) ⁶	% of ECEC	< 7%	
Exchangeable potassium (K) ⁶	% of ECEC	5-10%	
Exchangeable calcium (Ca) ⁶	% of ECEC	60-80	
Exchangeable magnesium (Mg) ⁶	% of CEC	15-25	
Exchangeable aluminium (Al) ⁶	% of CEC	< 2	
Exchangeable Ca/Mg ratio ⁶	ratio	3-9	
Available iron (Fe) ⁶	mg/kg	100-400	
Available manganese (Mn) ⁶	mg/kg	25-100	
Available zinc (Zn) ⁶	mg/kg	5-30	
Available Copper (Cu) ⁶	mg/kg	1-15	
Available boron (B) ⁶	mg/kg	0.5-5	
Available N (ammonium-N + nitrate-N) ⁶	mg/kg	> 25	

Method References

1. Texture (SESL)
2. Rayment & Lyons 6B2
3. Rayment & Lyons (2011)
4. AS4419-2018
5. AS4454-2012 Appendix 1
6. McIntyre & Jakobsen-1998
7. Emerson (1991)

Table 2: Specification 5 – Tree Pits, High Value, Top 300mm (A Horizon)			
Physical Properties			
Property	Units	Target Range	
Texture, preferred range ¹	n/a	Sandy loam to clay loam	
Organic matter ²	% dwb	3-6	
Permeability (@ 16 drops by McIntyre Jakobsen) ³	mm/h	> 30	
Wettability ⁴	mm/h	> 5	
Dispersibility in water ⁷	Class	> 4	Emerson Aggregate Class
Large particles (naturally occurring) ⁴			
2-20 mm	% w/w	< 20	
> 20 mm	% w/w	< 10	
Visible contaminants > 2 mm (glass, plastic and metal) ⁵	%w/w	< 0.5	
Physical Properties			
Property	Units	Target Range	
pH in water (1:5) standard range ⁶	pH units	5.4-6.8	
pH in CaCl2 (1:5) standard range ⁶	pH units	5.2-6.5	
Electrical conductivity (1:5) ⁶	dS/m	< 0.65	
Phosphorus – P-sensitive plants. Acid soils method ⁶	mg/kg	< 30	
Phosphorus – P-Tolerant plants. Acid soils method ⁶	mg/kg	30-60	
Exchangeable sodium (Na) ⁶	% of ECEC	< 7%	
Exchangeable potassium (K) ⁶	% of ECEC	5-10%	
Exchangeable calcium (Ca) ⁶	% of ECEC	60-80	
Exchangeable magnesium (Mg) ⁶	% of CEC	15-25	
Exchangeable aluminium (Al) ⁶	% of CEC	< 2	
Exchangeable Ca/Mg ratio ⁶	ratio	3-9	
Available iron (Fe) ⁶	mg/kg	100-400	
Available manganese (Mn) ⁶	mg/kg	25-100	
Available zinc (Zn) ⁶	mg/kg	5-30	
Available Copper (Cu) ⁶	mg/kg	1-15	
Available boron (B) ⁶	mg/kg	0.5-5	
Available N (ammonium-N + nitrate-N) ⁶	mg/kg	> 25	

Method References

1. Texture (SESL)
2. Rayment & Lyons 6B2
3. Rayment & Lyons (2011)
4. AS4419-2018
5. AS4454-2012 Appendix 1
6. McIntyre & Jakobsen-1998
7. Emerson (1991)

Table 3: Specification 7 – Tree Pits Under Pavement – Cell Systems			
Physical Properties			
Property	Units	Target Range	
Texture, preferred range ¹	n/a	Sandy loam to clay loam	
Organic matter ²	% dwb	3-6	
Permeability (@ 16 drops by McIntyre Jakobsen) ³	mm/h	> 30	
Wettability ⁴	mm/h	> 5	
Dispersibility in water ⁷	Class	> 4	Emerson Aggregate Class
Large particles (naturally occurring) ⁴			
2-20 mm	% w/w	< 20	
> 20 mm	% w/w	< 10	
Visible contaminants > 2 mm (glass, plastic and metal) ⁵	%w/w	< 0.5	
Chemical Properties			
Property	Units	Target Range	
pH in water (1:5) standard range ⁶	pH units	5.4-6.8	
pH in CaCl2 (1:5) standard range ⁶	pH units	5.2-6.5	
Electrical conductivity (1:5) ⁶	dS/m	< 0.65	
Phosphorus – P-sensitive plants. Acid soils method ⁶	mg/kg	< 30	
Phosphorus – P-Tolerant plants. Acid soils method ⁶	mg/kg	30-60	
Exchangeable sodium (Na) ⁶	% of ECEC	< 7%	
Exchangeable potassium (K) ⁶	% of ECEC	5-10%	
Exchangeable calcium (Ca) ⁶	% of ECEC	60-80	
Exchangeable magnesium (Mg) ⁶	% of CEC	15-25	
Exchangeable aluminium (Al) ⁶	% of CEC	< 2	
Exchangeable Ca/Mg ratio ⁶	ratio	3-9	
Available iron (Fe) ⁶	mg/kg	100-400	
Available manganese (Mn) ⁶	mg/kg	25-100	
Available zinc (Zn) ⁶	mg/kg	5-30	
Available Copper (Cu) ⁶	mg/kg	1-15	
Available boron (B) ⁶	mg/kg	0.5-5	
Available N (ammonium-N + nitrate-N) ⁶	mg/kg	> 25	

Method References

1. Texture (SESL)
2. Rayment & Lyons 6B2
3. Rayment & Lyons (2011)
4. AS4419-2018
5. AS4454-2012 Appendix 1
6. McIntyre & Jakobsen-1998
7. Emerson (1991)

SCALE ON ORIGINAL A3 SIZE DRAWING					DRAWN	-		CENTRAL COAST COUNCIL		STANDARD DRAWING		
					CHECKED	-						
					DATE	-		SPECIFICATION SERIES SOIL SPECIFICATION - SHEET 2		DRAWING NUMBER	REV	
					UNIT MANAGER APPROVAL					-	LSD801	A
REV	AMENDMENT	DATE	DRAWN	APRVD	ALL DIMENSIONS IN mm UNLESS OTHERWISE SHOWN					ASSETS PLANNING AND DESIGN	-	A3

Table 4: Specification 8 – Tree Pits Under Pavement – Structural Soils with Aggregates – Filler Soils

Physical Properties		
Property	Units	Target Range
Texture, preferred range ¹	n/a	Sandy loam to clay loam
Organic matter ²	% dwb	3-6
Wettability ⁴	mm/h	> 5
Dispersibility in water ⁷	Class	> 4
Large particles (naturally occurring) ⁴		
Gravel > 4mm ⁴	% w/w	< 20
> 20 mm	% w/w	< 10
Visible contaminants > 2 mm (glass, plastic and metal) ⁵	%w/w	< 0.5
Chemical Properties		
Property	Units	Target Range
pH in water (1:5) standard range ⁶	pH units	5.4–6.8
pH in CaCl ₂ (1:5) standard range ⁶	pH units	5.2–6.5
Electrical conductivity (1:5) ⁶	dS/m	< 0.5
Phosphorus – P-sensitive plants. Acid soils method ⁶	mg/kg	< 30
Phosphorus – P-Tolerant plants. Acid soils method ⁶	mg/kg	30-100
Exchangeable sodium (Na) ⁶	% of ECEC	< 7%
Exchangeable potassium (K) ⁶	% of ECEC	3–10%
Exchangeable calcium (Ca) ⁶	% of ECEC	60–80
Exchangeable magnesium (Mg) ⁶	% of CEC	15–25
Exchangeable aluminium (Al) ⁶	% of CEC	< 5
Exchangeable Ca/Mg ratio ⁶	ratio	3–9
Available iron (Fe) ⁶	mg/kg	100–400
Available manganese (Mn) ⁶	mg/kg	25–100
Available zinc (Zn) ⁶	mg/kg	5–30
Available Copper (Cu) ⁶	mg/kg	1–15
Available boron (B) ⁶	mg/kg	0.5–5
Available N (ammonium-N + nitrate-N) ⁶	mg/kg	> 20
Physical Properties – Aggregate Component		
Property	Units	Target Range
63.0	% Passing	100
53	% Passing	85-100
37.5	% Passing	20-65
26.5	% Passing	0-20
19.0	% Passing	0-5
13.2	% Passing	0-2
4.75	% Passing	0-1
Sodium Sulfate Soundness ⁹	% Weight loss	≤ 9

- Method References**
- Texture (SESL)
 - Rayment & Lyons 6B2
 - Rayment & Lyons (2011)
 - Wet Sieve Method
 - AS4454-2012 Appendix 1
 - McIntyre & Jakobsen-1998
 - Emerson (1991)
 - AS1141.11-2009
 - AS1141.24-1997

Table 5: Specification 9 – Turf, Low Traffic

Physical Properties		
Property	Units	Target Range
2.0 mm (fine gravel) ¹	% retained by mass	< 10
1.0 mm (very coarse sand) ¹		< 10
0.5 mm (coarse sand) ¹		10-30
0.25 mm (medium sand) ¹		20-40
0.1 mm (fine sand) ¹		10-30
0.05 (very fine sand) ¹		5-15 (max 20% combined v/s, Si +Cl)
0.002 mm (silt) ¹		< 12 (Si + Clay combined 5-8)
< 0.002 mm (clay) ¹		3-8
Large particles ²		2–20 mm = < 10% > 20 mm = 0%
Organic matter content ⁴		% w/w
Permeability ³	mm/hour	>30(@ 16 drops by McIntyre Jakobsen)
Wettability (AS 4419) ²	mm/hour	> 5
Dispersibility in water ⁶	Class	> 4 Emerson Aggregate Class
Chemical Properties		
Property	Units	Target Range
pH in water (1:5) ⁵	pH units	5.4–8.0
pH in CaCl ₂ (1:5) ⁵	pH units	5.2–7.5
Electrical conductivity (1:5) ⁵	dS/m	< 0.5
Exchangeable Na percentage ⁵	% of ECEC	< 7
Exchangeable Ca/Mg ratio ⁵	Ratio	3-9
Available phosphorus Mehlich 3 ⁵	mg/kg	50–150
Available phosphorus Olsen	mg/kg	20–50
Available nitrogen (nitrate N + ammonium N) ⁵	mg/kg	20-60

- Method References**
- AS1289.1632-2003
 - AS4419-2018
 - McIntyre & Jakobsen-1998
 - Rayment & Lyons 6B2
 - Rayment & Lyons (2011)
 - Emerson (1991)

Table 6: Specification 10 – Turf, High Traffic

Physical Properties		
Property	Units	Target Range
2.0 mm (fine gravel) ¹	% retained by mass	< 10
1.0 mm (very coarse sand) ¹		< 10
0.5 mm (coarse sand) ¹		10-30
0.25 mm (medium sand) ¹		20-40
0.1 mm (fine sand) ¹		10-30
0.05 (very fine sand) ¹		< 15 (max 20% combined v/s, Si +Cl)
0.002 mm (silt) ¹		< 8 (Si + Clay combined 5-8)
< 0.002 mm (clay) ¹		2-6
Large particles ²		2–20 mm = < 2% > 20 mm = 0%
Organic matter content ⁴		% w/w
Permeability ³	mm/hour	> 50-200 (@ 16 drops by McIntyre Jakobsen)
Wettability (AS 4419) ²	mm/hour	> 5
Dispersibility in water ⁶	Class	> 4 Emerson Aggregate Class
Chemical Properties		
Property	Units	Target Range
pH in water (1:5) ⁵	pH units	5.4–8.0
pH in CaCl ₂ (1:5) ⁵	pH units	5.2–7.5
Electrical conductivity (1:5) ⁵	dS/m	< 0.5
Exchangeable Na percentage ⁵	% of ECEC	< 7
Exchangeable Ca/Mg ratio ⁵	Ratio	3-9
Available phosphorus Mehlich 3 ⁵	mg/kg	50–150
Available phosphorus Olsen	mg/kg	20–50
Available nitrogen (nitrate N + ammonium N) ⁵	mg/kg	30-100

- Method References**
- AS1289.1632-2003
 - AS4419-2018
 - McIntyre & Jakobsen-1998
 - Rayment & Lyons 6B2
 - Rayment & Lyons (2011)
 - Emerson (1991)

Table 7: Specification 11 - Subgrade Specification

Physical Properties		
Property	Units	Target Range
Texture, preferred range ¹	n/a	Loam to clay loam
Structure	n/a	Required for calculation
Estimated permeability	mm/hr	> 20
Organic matter ²	% dwb	< 3
Chemical Properties		
Property	Units	Target Range
pH in water (1:5) standard range ⁶	pH units	5.4–6.8
pH in CaCl ₂ (1:5) standard range ⁶	pH units	5.2–6.5
Electrical conductivity (1:5) ⁶	dS/m	< 0.65
Exchangeable sodium (Na) ⁶	% of ECEC	< 7%
Exchangeable potassium (K) ⁶	% of ECEC	5–10%
Exchangeable calcium (Ca) ⁶	% of ECEC	60–80
Exchangeable magnesium (Mg) ⁶	% of CEC	15–25
Exchangeable aluminium (Al) ⁶	% of CEC	< 2
Exchangeable Ca/Mg ratio ⁶	ratio	3–9

- Method References**
- Texture (SESL)
 - Rayment & Lyons 6B2
 - Rayment & Lyons (2011)
 - AS4419-2018
 - AS4454-2012 Appendix 1
 - McIntyre & Jakobsen-1998
 - Emerson (1991)

REV	AMENDMENT	DATE	DRAWN	APRVD	SCALE ON ORIGINAL A3 SIZE DRAWING	DRAWN	-		CENTRAL COAST COUNCIL SPECIFICATION SERIES SOIL SPECIFICATION - SHEET 3	STANDARD DRAWING	
					CHECKED	-	DRAWING NUMBER			REV	
					DATE	-	LSD801			A	
					UNIT MANAGER APPROVAL						A3
					ALL DIMENSIONS IN mm UNLESS OTHERWISE SHOWN	ASSETS PLANNING AND DESIGN					

CENTRAL COAST COUNCIL LANDSCAPE SPECIFICATION

1. Construction Preliminaries

- 1.1 All Contractors will undertake all work in a manner that is compliant with relevant State and National legislated Workplace Health and Safety requirements.
- 1.2 The specification outlines Council's minimum acceptable standard. Any variations to these standards must be approved by Council prior to project commencement.
- 1.3 Project specific variations may be appropriate as a result of site environmental or other constraints. Site specific variations and solutions are to be approved by Council prior to project commencement.
- 1.4 Before works commence, the Head Contractor is to arrange a pre-start meeting with the Landscape Superintendent, relevant Council Officers, Contractor, Landscape Architect, Arborist and other consultants where applicable to clarify issues, agree on protocols, confirm hold point requirements and establish management procedures.
- 1.5 It is the responsibility of the Contractor to report any discrepancies within the landscape documentation and site conditions to the Landscape Superintendent for clarification and be fully resolved in writing prior to proceeding with the works.
- 1.6 Ensure that all appropriate barriers, signage, fencing and pedestrian / vehicle safety measures are in place before work commences.
- 1.7 The Contractor is to confine all works within the defined property boundaries and ensure all precautions to protect adjacent property, structures and vegetation from damage during construction are in place.
- 1.8 The Contractor is to seek confirmation with local authorities or similar as appropriate for all service locations prior to commencement of works. Ensure 'Dial Before You Dig' information is sourced and made available onsite at all times.
- 1.9 The Contractor shall be responsible at all times for the location on site of underground services that may be encountered within the vicinity of the works. For service location the following guidance should be followed:
Refer to local authority drawings where appropriate for all existing underground services.
- Refer to civil engineering drawings for all stormwater, water and sewer services including but not limited to conduits, pipes, service pits and access points.
- Refer to electrical engineering drawings for location of all electrical services including but not limited to conduits, cables, switch-boxes and service point locations.
- Refer to drawings by others for location of all telecommunication services including but not limited to conduits, cables and service location points.
- 1.10 Protect all existing services encountered during construction works in accordance with relevant local authorities' specifications.
- 1.11 The Contractor is responsible for environmental management to areas defined as the scope of works area, as well as areas outside the defined scope of works where the Contractor undertakes work inclusive of stockpiles, traffic access, site storage compound and the like. All environmental management procedures shall be confirmed with the Landscape Superintendent and Head Contractor prior to construction works commencing.
- 1.12 The Contractor is to install all sediment and erosion control measures and maintain throughout the course of the project as outlined in the Council approved Sediment and Erosion Control Management Plan (SEMP). A copy of the SEMP is to be available onsite at all times
- 1.13 Remove all weeds within the defined scope of works area as listed under the relevant Local and State Government declared plants and land protection legislation. No plant material listed within Local or State declared weed legislation shall be brought onto or installed on site.

2. Hold Points

- 2.1 All landscape works will require the hold points outlined in table 1 to be adhered to. The Contractor must ensure all hold points have been signed off by the Landscape Superintendent or relevant Council officer prior to continuation of work. Any variation to the hold points are to be approved by Council prior to commencement of works.

Table 1

Hold Point & Notice Period	Standards & Certificates	Required Personnel
1. Plant material and tree stock at nursery prior transportation to site (5 days notice prior to intended inspection date).	<ul style="list-style-type: none"> Natspec tree certification As 2303:2018 – tree stock for landscape use Pre-delivery certificate from the supplier certifying the plant stock is in accordance with natspec and as 2303:2018 All plant stock to be obtained from a registered supplier with accreditation from the Nursery Industry Accreditation Scheme Australia (NIASA) 	<ul style="list-style-type: none"> Landscape architect Landscape superintendent Council officer (internal projects)

Hold Point & Notice Period	Standards & Certificates	Required Personnel
2. Sub-grade cultivation (5 days notice prior to intended inspection date).	<ul style="list-style-type: none"> As 4419:2003 soils for landscaping and garden use In accordance with approved documentation drawings and specifications 	<ul style="list-style-type: none"> Landscape superintendent Council officer (internal projects)
3. Testing, amelioration, importation and placement of topsoils (7 days notice prior to intended inspection date).	<ul style="list-style-type: none"> As 4419:2003 soils for landscaping and garden use Central coast council soil specification LSD801 	<ul style="list-style-type: none"> Landscape superintendent Council officer (internal projects)
4. Identification of TPZ and planting / works within the zone (5 days notice prior to intended inspection date).	<ul style="list-style-type: none"> AS 4970 protection of trees on development sites Tpz as identified in AS 4970 section 3 Arborist report 	<ul style="list-style-type: none"> Landscape architect Landscape superintendent Arborist Aouncil officer (internal projects)
5. Setout of street trees and landscape areas (5 days notice prior to intended inspection date).	<ul style="list-style-type: none"> Approved landscape plans 	<ul style="list-style-type: none"> Landscape architect Landscape superintendent Council officer (internal projects)
6. Preparation of tree pits and garden beds including excavation, drainage, root barriers and soil additives (5 days notice prior to intended inspection date).	<ul style="list-style-type: none"> Approved landscape plans Compost and soil certificates Inspection report of supplied plant stock 	<ul style="list-style-type: none"> Landscape superintendent Council officer (internal projects)
7. Practical completion of landscape works	<ul style="list-style-type: none"> Approved landscape plans Landscape implementation and compliance report 	<ul style="list-style-type: none"> Landscape Architect Landscape Superintendent Council Officer

3. General Requirements

- 3.1 All landscape works are to be carried out in a manner consistent with industry best practice and guidelines presented in this specification and documentation drawings.
- 3.2 This specification is to be read in conjunction with the Central Coast Council Soil Specification LSD801.
- 3.3 Representative samples of each landscape material outlined in the drawing schedules are to be submitted to the Landscape Superintendent, packed as to prevent cross contamination and labelled to indicate source and content.
- 3.4 No plants, plant sizes or quantities are to be substituted or altered without prior approval of the Landscape Superintendent and Council Officer.
- 3.5 Any alternatives to documented products, methods or systems must be accompanied by sufficient information to allow a thorough evaluation by the Landscape Superintendent and Council Officer prior to approval. All variations are to be approved by the Landscape Superintendent and Council Officer prior to commencement of works.
- 3.6 If the substitution is for any reason other than availability, submit evidence that the substitution is of;
 - Net enhance value to the project
 - Consistent with the project design intent, approved documentation drawings and is as effective as the identified item, detail or method.

4. Tree Protection

- 4.1 All tree protection measures for existing trees to be retained are to be in accordance with AS 4970: Protection of Trees on Development Sites.
- 4.2 All pruning works on existing trees to be protected are to be in accordance with AS 4373: Pruning of Amenity Trees. An authorized and suitably qualified arborist must identify and approve trees that require pruning work prior to commencement of works.
- 4.3 Clearance of vegetation and removal trees not indicated on the approved drawings as 'to be removed' is prohibited without approval from the Landscape Superintendent and Council Officer.

- 4.4 Prior to work commencing, a Tree Protection Zone (TPZ) shall be established around all trees identified for retention within or immediately adjacent to the works area and must remain in place for the duration of the works.
- 4.5 Clearly mark which trees are to be retained and protected. Display a sign in a prominent position at each entrance to the site, warning that trees are to be protected during the construction period. Provide a tree protection measures program before commencing works.
- 4.6 The TPZ as identified in AS 4970 Section 3 is to be adhered to. Activities within the TPZ that are to not take place, unless otherwise stated include:
 - Modification of existing soil levels, excavations, trenching or movement or rock
 - Mechanical removal of vegetation
 - Storage of materials, plant or equipment or erection of site sheds
 - Affixing of signage or hoarding to the trees
 - Preparation of building materials, refueling or disposal of waste materials and chemicals
 - Lighting fires
 - Movement of pedestrian or vehicular traffic
 - Temporary or permanent location of services, or the works required for their installation
 - Any other activities that may cause damage to the tree
 - If access, encroachment or incursion into the TPZ is deemed essential, prior authorisation is required by a qualified arborist and the Landscape Superintendent.
- 4.7 Temporary fencing or protective enclosures to the approval of the authorised arborist and Landscape Superintendent shall be erected on the edge of the TPZ excluding access to the area within at all times.
- 4.8 Where work is required to be undertaken within the TPZ, it is to be supervised by the authorised arborist and fenced enclosures in place around the specific tree/s to minimise damage to the tree and rootzone.
- 4.9 Root pruning where required shall be undertaken via the use of a clean and sharp implement minimising surface areas of the wounds. All roots with a diameter of 50mm or greater must be inspected by the authorised arborist prior to cutting.
- 4.10 Apply root hormone solution directly to cut roots if they are exposed during excavation. Alternatively, if the construction method does not expose roots, drench the zone at the surface with the root hormone solution. Apply the solution at the rates and intervals recommended by the manufacturer.
- 4.11 All significant damage to trees that occurs by accident or as a result of unapproved work methods will require rectification works to the satisfaction of the authorised arborist and Council Officer. All costs associated with the rectification works are to be incurred by the Contractor.
- 4.12 Where trees to be retained are removed or are damaged to an extent that requires removal, the Contractor is to pay damages valued according to DR 99307: Amenity Trees Guide to Valuation, unless a value is nominated for a specific tree or agreed to by the Council Officer.

5. Landscape Works

- 5.1 For soil properties, testing and procedures, refer to the Central Coast Council Soil Specification LSD801.
- 5.2 Turf shall be installed onsite within 36 hours of cutting. Turf is to be supplied from a specialist grower and be of an even thickness, free from weeds and other foreign matter and be accompanied by a 'Certificate of Authenticity'. Fertiliser must be applied to the topsoil and mixed evenly through prior to installation of the turf. Turf shall be rolled evenly at installation and be maintained even, free from dips, lumps and trip hazards throughout the establishment period. The watering, mowing and establishment of all turf areas will remain the responsibility of the Contractor at all times during the establishment period.
- 5.3 Species of turf is to be in accordance with the approved drawings and Council Officer. The turf shall contain minimum 90% of the specified species and be weed free.
- 5.4 Turf to be laid along contours with staggered, close butted joints, graded evenly with no hollows, so that finished turf surface is level with adjacent surface levels.
- 5.5 Mulch is to be free of damaging materials such as soil, weeds, rocks, sticks and other foreign matter and comply with the requirements set out in AS 4454:2012 Composts, Soil Conditioners and Mulches.
- 5.6 Site obtained mulch from tub-ground native vegetation is to be processed either through a tub grinder or chipper and be weed free. Stockpiled mulch shall be aged for minimum 2 months after chipping prior to being spread in the designated areas to avoid nitrogen draw down of the soils.
- 5.7 Mulch is to be spread immediately after planting to prevent erosion, loss of soil moisture and weed infestation. Depths and types of mulch to be in accordance with the approved landscape drawings, kept clear of plant stems, and raked to an even surface flush with the surrounding finished levels or as per the details on the approved landscape drawings.
- 5.8 Hydromulching to be a slurry mixture of seed, fertilizer, mulch and water applied at the rates as scheduled on the approved landscape drawings, thoroughly mixed in a purpose-made mechanical mixer and applied by high pressure pumping equipment by an appropriately trained operator. The mixture is to be evenly distributed over a scarified surface providing a firm friable seed bed.
- 5.9 Trees supplied to site are to have a well-established single leader, unless otherwise specified. Bifurcated trees with included bark will not be accepted regardless of species and habit. Trees that do not comply with the NATSPEC tree stock selection criteria and AS 2303:2018 may be rejected on arrival to site.
- 5.10 Trees to be installed as per the Central Coast Council standard details
- 5.11 Tree location, size and quantities are to be set out as per the approved landscape drawings, unless directed by the Landscape Superintendent or Council Officer.
- 5.12 Tree planting pits are to be excavated to a size and depth as indicated in the approved landscape drawings. Contact Landscape Superintendent or Council Officer if there are conflicts with underground services.
- 5.13 Street tree setout must be in accordance with Central Coast Council requirements in

relation to offsets to paths, services, lights, driveways and road infrastructure as shown in Table 2

Table 2

Street Tree Positioning	
Item	Minimum distance
Kerb and footpath	600-1000mm behind back of kerb (where possible) or centrally located between kerb and footpath (future or existing), dependent on verge width
Driveways	3m
Light poles	5m
Stormwater pits	3m
Adjacent underground services	1m or according to the service provider
Street corner intersections	6m from kerb tangent point

- 5.14 The Contractor is to supply and install plants as per the approved landscape drawings and schedules.
 - 5.15 Plants are to be healthy, vigorous, well-established, free from weeds, pests and diseases and of good form consistent with the species or variety. Root bound pots will be rejected.
 - 5.16 Plants are to be hardened off for the prevailing site conditions, not soft or forced and conditioned to be suitable for planting in the natural climatic conditions of the site.
 - 5.17 Plants are to be delivered to site in a covered vehicle to reduce the effect of wind damage, transpiration and stress. If plants are to be stored onsite prior to planting, ensure they are protected from winds and construction activities. Water plants thoroughly once a day or as required for every day they are stored on site.
 - 5.18 Do not plant in unsuitable weather conditions such as extreme heat, cold, wind or rain. In other than sandy soils, suspend excavation when the soil is wet or during frost periods.
 - 5.19 When planting, remove the plant from the container with minimum disturbance to the root ball. Ensure the root ball is moist and place it in its final position, in the centre of the hole and plumb, and with the top soil level of the plant root ball level with the finished surface of the surrounding soil. Compact lightly so as to minimize subsidence without compacting the backfill. Avoid mixing mulch with topsoil.
 - 5.20 Thoroughly water the plants before planting, immediately after planting and as required to maintain growth rates free of stress.
- 6. Plant Procurement**
- 6.1 Advanced trees and specimen plants are to be ordered immediately upon awarding of the contracted landscape works to ensure the availability at the time of planting. No substitutes will be accepted due to not placing plant procurement orders in a timely manner. Evidence of a plant procurement contract in place between the plant supplier and purchaser is to be presented to the Landscape Superintendent and Council Officer as proof of ordering.
 - 6.2 Submit photographic examples of all trees greater than 75L pot and any specimen plant species to the Landscape Superintendent. The photographs are to be clear, in colour, identifiable scale reference located in the same plane as the plant trunk and labelled with plant species name.
 - 6.3 A Tree Inspection Form is to be completed by the Landscape Superintendent at the time of inspection for each batch inspected. Non-conforming plants may be rejected or corrective action procedures put in place to ensure conformity at the time of delivery. Trees will follow the assessment criteria outlined in AS 2303.
 - 6.4 For trees and shrubs in small containers, Table 3 shall be referenced to make a balanced assessment of the size of the plant appropriate to the container size at the time of delivery.

Table 3

Small Container Grown Trees and Shrubs Table		
Container size	Height above soil (m)	
	Thin-stemmed species	Thick-stemmed species
Tubes or plant cells	1.5 to 2.5 x the height of the container	
150mm (1.8l)	0.4 – 0.6	0.3 – 0.5
170mm (2.6l)	0.5 – 0.7	0.4 – 0.6
200mm (4l)	0.7 – 0.9	0.6 – 0.8
250mm (8l)	1.0 – 1.2	0.8 – 1.0
200mm (15l)	1.2 – 1.5	1.0 – 1.2

REV	AMENDMENT	DATE	DRAWN	APRVD	ALL DIMENSIONS IN mm UNLESS OTHERWISE SHOWN	ASSETS PLANNING AND DESIGN	SCALE ON ORIGINAL A3 SIZE DRAWING	DRAWN	-		CENTRAL COAST COUNCIL		STANDARD DRAWING	
								CHECKED	-		SPECIFICATION SERIES LANDSCAPE SPECIFICATION - SHEET1	DRAWING NUMBER	REV	
								DATE	-			LSD802	A	
							UNIT MANAGER APPROVAL							

CENTRAL COAST COUNCIL LANDSCAPE SPECIFICATION

- 6.5 For large container trees above 20L, AS 2303 Appendix E, Table E1 is to be referenced for tree supply conformance. Sampling of the batch is to be in accordance with AS 2303 Appendix A, Table A1.
- 6.6 A contingency of 15% above the quantities scheduled on the approved landscape drawings is to be grown by the supplier to allow for the anticipated losses in the course of propagation, growing on and replacement of failure on site during the establishment period. Any surplus material shall remain the property of the supplier.
- 6.7 A certificate of warranty from the supplier is to be issued to the Landscape Superintendent and Council Officer at the time of each delivery confirming that the plants supplied are true-to-species type, free of disease and fungal infection and/or any other impediment to their future growth and that they have been fully acclimatized for the conditions of the site.

7. Establishment & Maintenance

- 7.1 The Contractor is to maintain the whole of landscape works for the period outlined in the Conditions of Consent from the date of Practical Completion up to the final handover to Council.
- 7.2 Following completion of the landscape works, a Practical Completion inspection is to be undertaken by the Landscape Superintendent, Landscape Architect and Council Officer. A Practical Completion Report is to be prepared by the Landscape Superintendent and issued to the Council. The report will outline any defects or rectification works to be undertaken by the Contractor and confirm that the landscape works have been installed as per the approved landscape documentation.
- 7.3 Throughout the Establishment and Maintenance Period, the Contractor is continue to carry out recurrent works of a maintenance nature including but not limited to watering, mowing, weeding, fertilizing, top dressing, rubbish removal, pest and disease control, staking and tying, replanting, cultivating, pruning and keeping the site neat and tidy.
- 7.4 The Contractor shall assume there is no site water available other than that which is provided as part of the works. The Contractor shall be responsible for supplying water and / or paying for water for the duration of the works. The Contractor shall provide a methodology of watering operations to the Landscape Superintendent for approval prior to commencement. Watering shall be done at the times of day to minimize water evaporation loss. Do not water during the hottest period of the Summer days. Adhere to any Local, State or Federal legislated water restrictions at the time of the works.
- 7.5 Tables 4 & 5 shall be used a guide for watering of free stock. The frequency will vary depending on weather conditions during the Establishment & Maintenance Period.

Table 4

Tree Watering Frequency Table			
Time of year	1st Month	2nd & 3rd Month	Establishment period
Sep-Feb	4 x Per week	3 x Per week	2 x Per week
Mar-May	3 x Per week	2 x Per week	1 x Per week
Jun-Aug	2 x Per week	1 x Per week	1 x Per fortnight

Table 5

Tree Container Size / Volume of Water Per Watering Cycle		
Container size	Free draining soil	Heavy Soil / Clay
45lt	10lt	5lt
100lt	20lt	15lt
150lt	30lt	20lt
200lt	40lt	30lt
250lt	50lt	35lt
300lt	60lt	45lt
400lt	80lt	60lt
500lt	100lt	75lt

- 7.6 The Contractor is to keep a Maintenance Logbook for the duration of the Establishment and Maintenance Period, verifying that satisfactory maintenance of the works has been conducted and that any necessary rectification measures have been carried out to a high professional standard. The Maintenance Logbook is to be made available at anytime to the Landscape Superintendent and Council Officer.
- 7.7 The Contractor is to continue to replace failed, damaged or stolen plants for the full extent of the Establishment and Maintenance Period. Should theft, vandalism or failure of particular species continue as an ongoing issue, contact the Landscape Superintendent, Principal and Council Officer to agree on appropriate solution.
- 7.8 Quarterly inspections are to occur with the Landscape Superintendent, Contractor and Council Officer. A report accompanied by photos is to be prepared by the Landscape Superintendent summarising the inspection outcomes and providing any recommendations for rectification works to be carried out. The reports will be made available to Central Coast Council as part of the Final Handover process.
- 7.9 At the end of the Establishment and Maintenance Period, a Final Handover Inspection is to be conducted between the Landscape Superintendent, Contractor and Council to determine that the landscape works have established adequately and to the approval of Council.

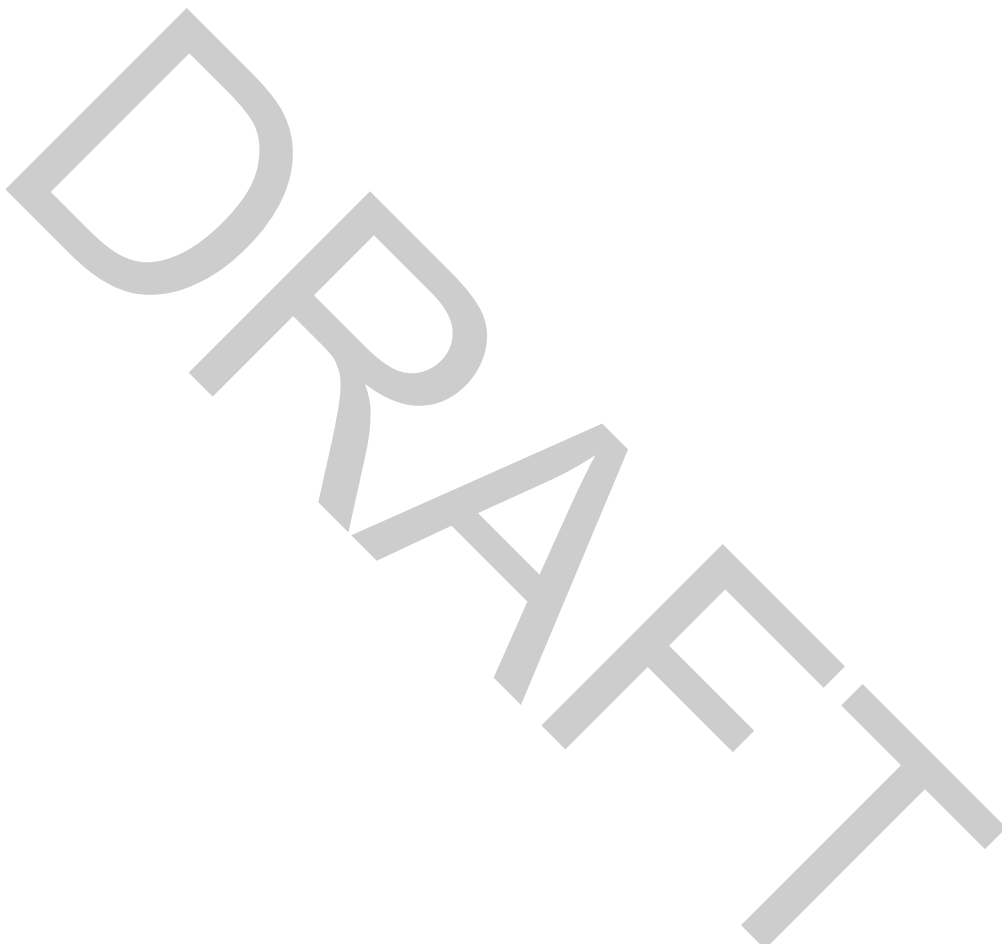

REV	AMENDMENT	DATE	DRAWN	APRVD	ALL DIMENSIONS IN mm UNLESS OTHERWISE SHOWN	SCALE ON ORIGINAL A3 SIZE DRAWING	DRAWN	-		CENTRAL COAST COUNCIL SPECIFICATION SERIES LANDSCAPE SPECIFICATION - SHEET 2	STANDARD DRAWING	
							CHECKED	-			DRAWING NUMBER	REV
							DATE	-			LSD802	A
							UNIT MANAGER APPROVAL				-	
					ASSETS PLANNING AND DESIGN							